



# Owner's & User's Manual

Safety Information, Installation and Care & Maintenance Instructions.

## Rectangle Trampoline Range



**Warning:** Read this manual before assembling and using the trampoline.

# INDEX

|   |            |
|---|------------|
| <b>SAFE USE INFORMATION .....</b>   | <b>3</b>   |
| <i>Important Notes.....</i>   | <i>3</i>   |
| <i>Reducing Risk of Injury While Using the Trampoline .....</i>                       | <i>4</i>   |
| <i>Safe Use Warning .....</i>   | <i>5</i>   |
| <i>Basic Trampolining Instructions .....</i>  | <i>5</i>   |
| <i>Basic Trampoline Bounces .....</i>   | <i>6</i>   |
| <i>Trampoline User Lesson Plan .....</i>  | <i>7</i>   |
| <b>TRAMPOLINE LOCATION.....</b>   | <b>8</b>   |
| <i>Correct Trampoline Positioning .....</i>   | <i>8</i>   |
| <b>FRAME, JUMPING MAT, AND SAFETY PADS ASSEMBLY .....</b>                             | <b>10</b>  |
| <i>Parts List (All Sizes) .....</i>   | <i>10</i>  |
| <i>Step 1 - Frame (All Sizes).....</i>  | <i>11</i>  |
| <i>Step 2 - Leg (All Sizes) .....</i>   | <i>16</i>  |
| <i>Step 3 - Frame (7x10ft &amp; 8x12ft).....</i>                                      | <i>16</i>  |
| <i>Step 3 - Frame (9x14ft &amp; 10x17ft) .....</i>                                    | <i>19</i>  |
| <i>Step 3 - Frame (14x16ft) .....</i>   | <i>21</i>  |
| <i>Step 4 - How to Use the Spring Tool (All Sizes) .....</i>                          | <i>23</i>  |
| <i>Step 5 - Jumping Mat &amp; Safety Pad with Protection Barrier (All Sizes).....</i> | <i>24</i>  |
| <b>SAFETY NET ASSEMBLY.....</b>   | <b>27</b>  |
| <i>Before Assembling the Safety Net Enclosure (All Sizes) .....</i>                   | <i>27</i>  |
| <i>Entrance Location (All Sizes) .....</i>  | <i>27</i>  |
| <i>Step 6 - Attaching the Safety Net Enclosure (7x10ft &amp; 8x12ft) .....</i>        | <i>27</i>  |
| <i>Step 6 - Attaching the Safety Net Enclosure (9x14ft) .....</i>                     | <i>33</i>  |
| <i>Step 6 - Attaching the Safety Net Enclosure (10x17ft).....</i>                     | <i>40</i>  |
| <i>Step 6 - Attaching the Safety Net Enclosure (14x16ft).....</i>                     | <i>47</i>  |
| <b>LADDER INSTALLATION .....</b>  | <b>533</b> |
| <b>CARE AND MAINTENANCE INSTRUCTIONS .....</b>  | <b>534</b> |
| <b>USER INSPECTION CHECKLIST .....</b>  | <b>55</b>  |

## SAFE USE INFORMATION

There is no doubt that trampolines can provide a lot of fun, entertainment, fitness and enjoyment. They also encourage the development of gross motor skills an incentive and opportunity to participate in physical activity and an environment where a user can challenge themselves to find and test their limits. However, like many physical activities, trampoline use involves the potential risk of injury, especially if the trampoline is used incorrectly. Misuse and abuse of this trampoline is dangerous and can cause serious injury!

Injury surveillance and hospital records show that trampolines are a frequent contributor in injury cases. Children under 14 years of age account for about 90% of all trampoline-related injuries. Children sustained 28% of the trampoline-related injuries under five years of age and more than a third of the injuries related to multi-users (Victorian Injury Surveillance Unit - Hazard 75, Autumn 2013, pg. 3).

### Important Notes:

1. Injury data indicates that people can be severely injured if they land on an unprotected trampoline frame or springs or if they fall from a trampoline. Soft edge systems and pads covering the frame/suspension system are intended to minimise the risk of injury while enclosure systems are intended to stop people falling off the trampoline. Ensure pads and enclosures are attached to the trampoline before use.
2. Trampolines, being rebound devices, can propel the user to unaccustomed heights and into a variety of unexpected body movements and positions. The risk of injury increases when more than one person at a time bounces on a trampoline. Multiple users on the trampoline can collide unexpectedly and uncontrollably into each other with force. Weight variations between users can compound this. Smaller children are particularly susceptible to increased risk of injury when jumping with adults and larger children, for example, a “double bounce” dramatically increases the energy transferred to the smaller body and children’s legs have been broken and severe spinal injuries have occurred as a result. Ensure only one person at a time bounces on the trampoline.
3. Children are often unable to identify hazards and do not have a well-developed ability to assess risk and may, if left unsupervised, be at more risk of injury.
4. Always supervise children when they are using the trampoline.
5. Overconfidence is a known precursor to higher risk taking which can lead to injury.
6. Learn the fundamental bounces first before trying more complex manoeuvres.
7. Inappropriate clothing can cause injury. Clothing should allow plenty of body movement without flapping loosely and becoming a distraction to the jumper.
8. Don’t wear any clothing that contains drawstrings, hooks, loops or anything that could get caught while using the trampoline which may cause entanglement or strangulation. Buckles, jewellery and belts should not be worn, as these may damage the trampoline mat or cause injury to the jumper if they become caught in the fabric of the trampoline. If you are a beginner, then you may want to wear a long-sleeved top and pants to protect yourself from scrapes and abrasions until you master control of bouncing and landing.
9. Shoes should be removed as they may damage the bed and increase the risk of injury.
10. Better design, good construction and improved safety features go a long way toward minimising the hazards associated with trampoline use. However, trampolines need to be used, cared and maintained appropriately to ensure benefits of these features throughout the life of the product.

## Reducing the Risk of Injury

While using the trampoline, develop household rules such as the following:

1. Do not allow children under the age of 6 years on the trampoline.
2. Allow only one person on the trampoline at a time.
3. Active, competent supervision is essential. Always supervise children while they are using the trampoline.
4. Ensure pads covering the frame/suspension system are securely attached at all times.
5. Ensure the enclosure is securely attached and in good condition at all times. Only use the trampoline with the enclosure entrance fully shut.
6. Check the trampoline before use and ensure it is in good condition. Replace any worn or broken parts. Use only parts that are recommended by the manufacturer.
7. Make sure the area around, underneath and above the trampoline is clear of objects that could interfere with the person jumping. Do not allow children, pets, toys or any other object to be present under the trampoline.
8. Adults should model the safe use of trampolines when children are present.
9. Wear comfortable clothing that won't become entangled in the trampoline's components and become a strangulation hazard. Do not wear jewellery or drawstrings/cords that can catch on the trampoline and create a strangulation hazard. Remove shoes as they may damage the bed and increase risk of injury.
10. Children should be educated by responsible adults to always "climb" on and off the trampoline in a controlled and careful manner and to never "jump or bounce" off (this is a dangerous practice when dismounting). Never use springs or suspension elements as "hand grips" when getting on or off the trampoline. Changing heights either up or down has its set of risks to injury, so whenever getting on or off the trampoline: don't rush, take deliberate care and always use full 3-point body contact with the trampoline at all times.
11. Learn fundamental bounces and body positions thoroughly before trying more advanced manoeuvres. A variety of trampoline activities can be carried out by performing the fundamentals in various series and combinations or performing one fundamental bounce after the other, with or without bounces between them. Review the "Basic Trampoline Bounces" section in this manual.
12. For further information or additional instructional material, contact the supplier. To learn more advanced trampolining skills, contact a suitable gymnastics/trampoline club.

## Safe Use Warning

**Note:** The warning label below is what your trampoline will have, except the model you have will also have the actual kg rating instead of the "X".

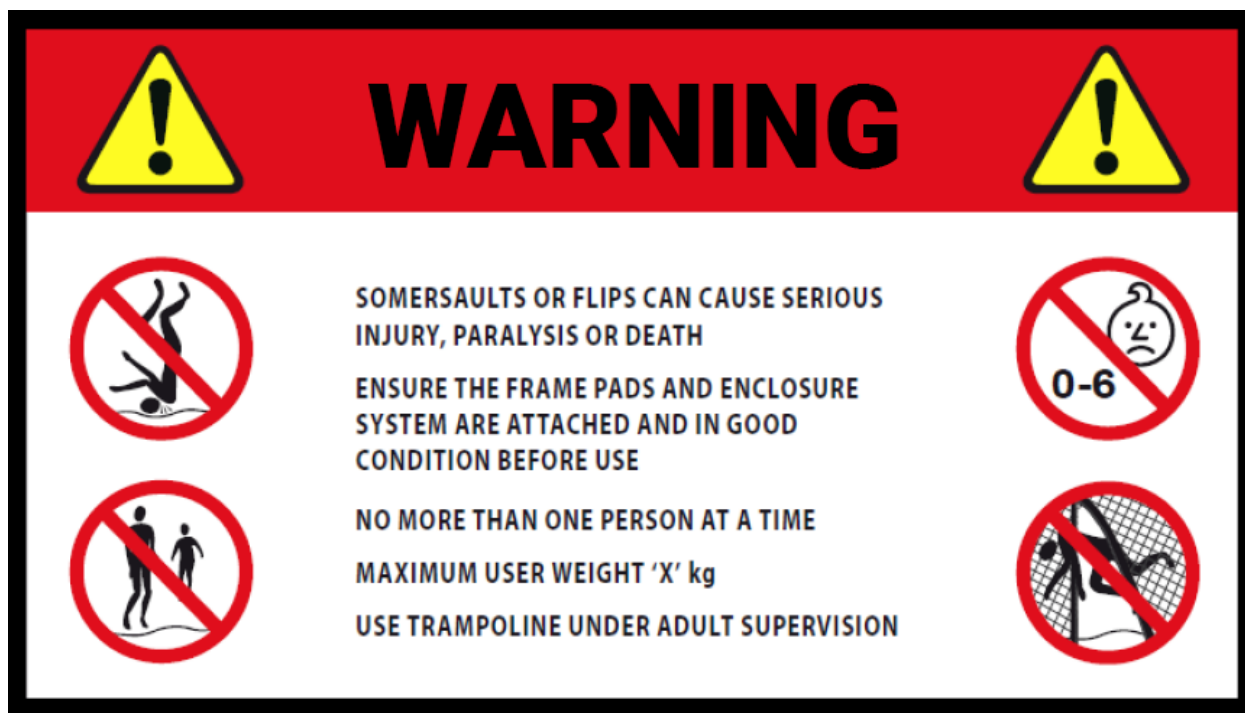

## Basic Trampolining Instructions

This trampoline is a domestic trampoline, not a gymnastics trampoline. You will get the safest and best use from it by following these basic principles:

1. Do not attempt or allow somersaults on the trampoline. Landing on your head or neck while doing somersaults can cause serious injury, paralysis or even death.
2. Do not use the trampoline when wet. The mat will be slippery and make landing less safe.
3. Enclosure systems are designed to prevent users falling off the trampoline. Do not allow users to intentionally bounce toward or off the barrier, as this can unbalance the trampoline and continual impact may damage the enclosure.
4. Do not use the trampoline while under the influence of alcohol or drugs. Balance, perception and assessment of risk will be affected and may lead to injury.
5. Do not use the trampoline as a springboard onto or into another object e.g. another nearby trampoline, swimming pool, etc. Use the trampoline only for trampoline style bouncing.
6. Focus your eyes on the edge of the trampoline. This will help control your bounce.
7. Stop your bounce by flexing your knees as your feet meet the trampoline bed. Learn this skill before you attempt any others.
8. Avoid bouncing too high. Stay low until you can control your bounce and repeatedly land in the centre of the trampoline.
9. Do not bounce immediately after a meal.

## Basic Trampoline Bounces

### The Basic Bounce

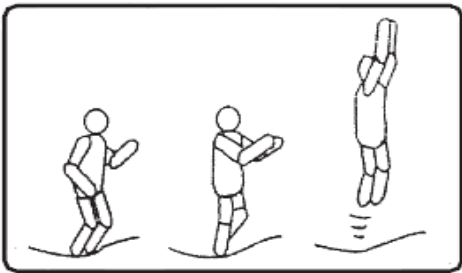

1. Start from the standing position with feet at shoulder width apart, head up and eyes focused on the mat.
2. Swing arms forward, up and around in circular motion.
3. Bring feet together while in mid-air and point toes downward.
4. Keep feet at shoulder width apart when landing on mat

### The Hands & Knee Bounce

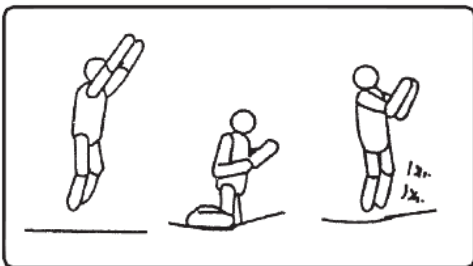

1. Start with the Basic Bounce and keep it low.
2. Land on knees while keeping back straight, body erect and using your arms to maintain balance.
3. Bounce back to the Basic Bounce position by swinging your arms up.

### The Seat Bounce

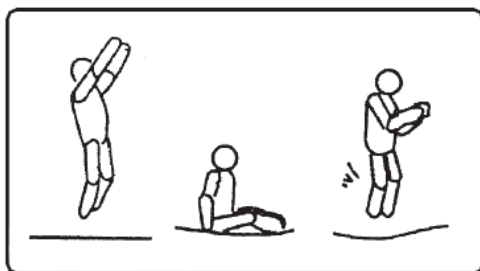

1. Land in a flat sitting position.
2. Place hands on the mat beside your hips.
3. Return to an erect position by pushing down on the mat with your hands.

### The Frontal Bounce

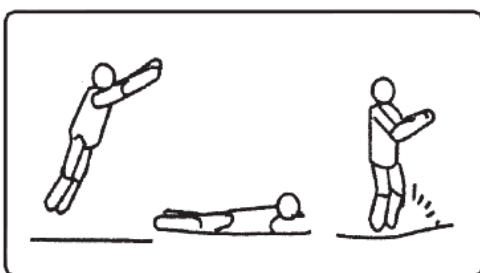

1. Start with Front Bounce position.
2. Land in prone (face down) position.
3. Position and keep your hand and arms extended forward on the mat.
4. Push off the mat with arms to return to standing position.

### The 180 Degree Bounce

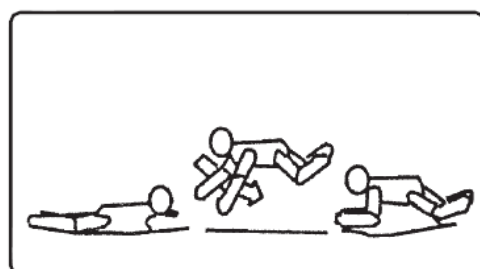

1. Start with the Frontal Bounce position.
2. Push off with left or right hands and arms (depending which way you want to turn).
3. Maintain head and shoulders in the same direction and keep back parallel to mat with your head up.
4. Land in a prone position by returning the standing position by pushing up with your hands and arms.

# Trampoline User Lesson Plan

Before actually getting on and using the trampoline you should have read and understood all safety instructions. A complete discussion and demonstration of body mechanics and trampoline guidelines should occur between the supervisor and the student user.

The following lessons are suggested to learn the basic steps and bounces. Before moving onto more difficult, complicated bounces, always start with low bounce heights.

## Lesson 1

1. Mounting/Dismounting: Demonstrate safe technique for getting on & off the trampoline.
2. The Basic Bounce: Demonstration and practice.
3. Stopping your bounce: Demonstration and practice of how to stop on command.
4. Hands & Knees: Demonstration and practice four-point landing and body alignment.

## Lesson 2

1. Review and practice techniques learned in Lesson 1.
2. The Hands & Knee Bounce: Demonstration and practice. Learn how to do the Basic Bounce and back up before half twist to the left and right.
3. The Seat Bounce: Demonstration and practice. Learn the basic Seat Bounce then add a Hands and Knees Bounce then repeat.

## Lesson 3

1. Review and practice techniques learned from previous lessons.
2. The Frontal Bounce: To avoid mat burns and to teach the frontal bounce position, the user should be requested to assume the prone position (face down on the mat) while the supervisor checks for faulty positions that could cause an injury.
3. Start with the Hands and Knees Bounce and then extend body into prone position, land on the mat and return to feet (standing position).
4. Practice Routine: the Hands and Knees Bounce, Frontal Bounce, back to feet, the Seat Bounce, back to feet.

## Lesson 4

1. Review and practice techniques learned from previous Lessons.
2. The 180 Degree Bounce (half turn).
3. After completing the above lessons, the student user now has the foundation of Trampoline Bounces. Users should be encouraged to develop their routines with the emphasis on staying in control. A game that can be played to encourage users to try and develop routines is "BOUNCE". In this game, the first player starts with a manoeuvre then the second player must do the first player's manoeuvre and add their own. The third player does the manoeuvres of player 1 & 2 and then adds a third manoeuvre. This continues until a player cannot do the routine; when a player makes a mistake, they receive a letter 'B'. Continue until someone spells the word "BOUNCE". The last person to spell this word is the winner. Even when playing this game, it is important for the players to perform their routines while staying in control and not try difficult or highly skilled bounces that have not been mastered. A certified trampoline instructor should be contacted to develop your trampoline skills further.

# TRAMPOLINE LOCATION

## Correct Trampoline Positioning

For safe use of the trampoline, please be aware of the following points when selecting a place for your trampoline:

1. Make sure the surface area is flat and level.
2. Make sure the surface is firm and stable to prevent the trampoline from tipping over.
3. Make sure the surface has impact attenuating properties such as grass or approved safety matting.
4. Do not place the trampoline on concrete or similar hard surfaces as this will cause higher wear rates on the trampoline joints which can affect your warranty.
5. Keep a minimum of 5m overhead clearance when measured from the trampoline bed height to prevent users inadvertently contacting overhead hazards such as electric wires, tree limbs, clotheslines and other possible hazards.
6. Maintain a minimum clearance of 1.5m on all sides of the trampoline. This area should not include hard surfaces (concrete, bitumen, brick, stone, etc.), recreational items (cubbies, swing sets, swimming pools) or other structures and equipment (electrical wiring, walls, fences, washing lines). These can cause serious injuries if users fall off the trampoline. This is also important due to the natural take up of weight if the users end up pushing or falling against the netting when the netting can be temporarily forced outside the natural trampoline frame circumference.
7. Make sure the position of the trampoline is not exposed to high winds.  
**Note:** The surface area of the mat and the net makes the trampoline susceptible to high winds. The trampoline can become airborne and move uncontrollably and do major damage to itself or anything in its path. As an example, trampolines can become airborne and become entangled in power lines creating secondary hazards. For trampolines not sheltered from high winds trampoline wind anchor kits may be suitable anchorage devices, or for lower risk wind exposed areas then sandbags may be an option. For further suggestions on securing your trampoline contact your supplier.
8. Make sure the area has good lighting.
9. Do not locate the trampoline on top of other objects or store anything underneath the trampoline bed.  
**Note:** Children have been injured while bouncing on trampolines and landing on garden tools, bikes, etc.
10. Make sure the position of the trampoline does not put users at risk from other hazards, for example recreational or road vehicles, other people, pets, animals, etc.
11. Trampoline accessories that are specifically designed for use with trampolines, whether sold with the trampoline or sold separately (e.g. tents), do not eliminate any of the requirements above.





**Warning:** Carefully check the below trampoline positioning to prevent damage or injury.

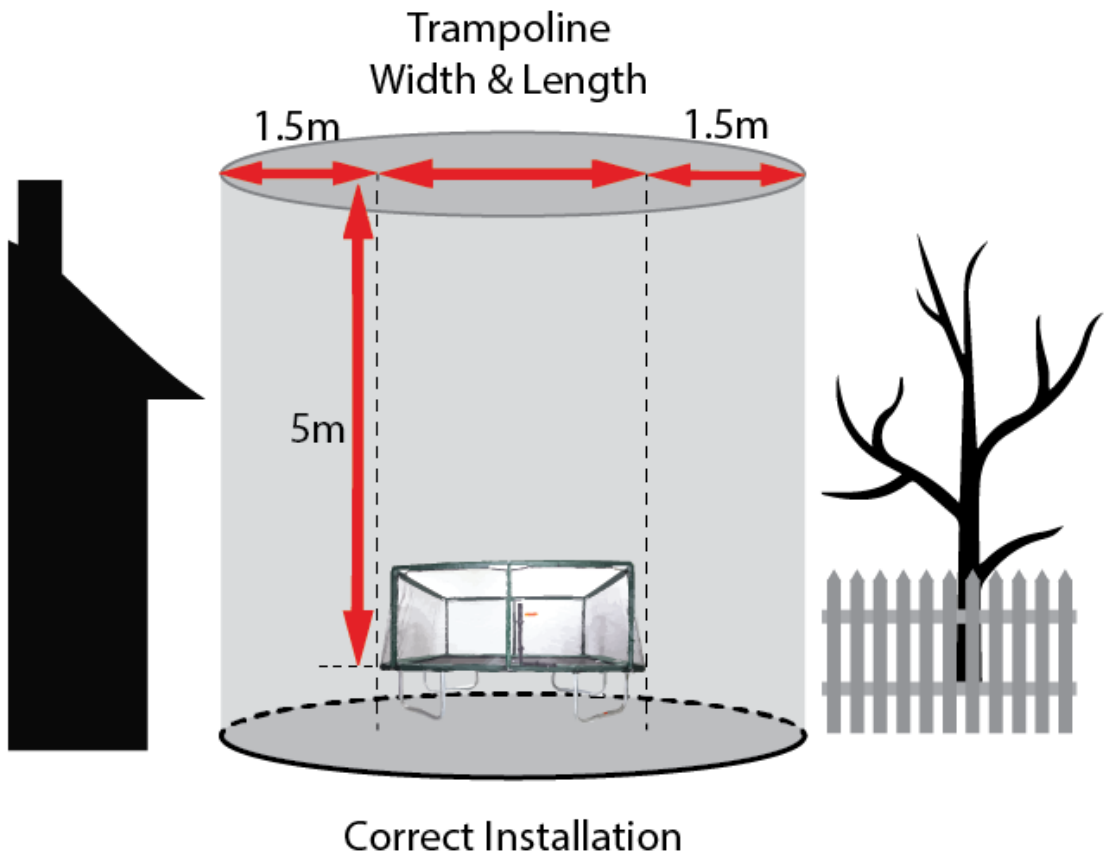
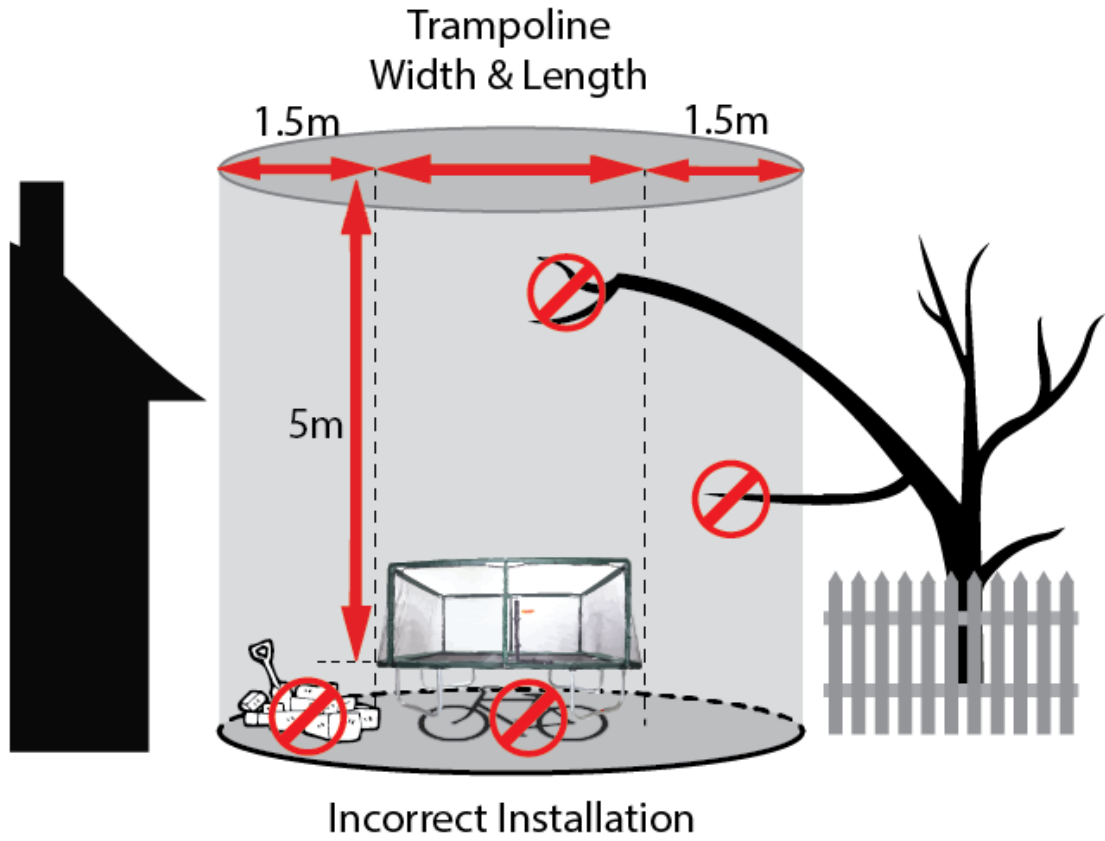

**Note:** The above images are not to scale.

# FRAME, JUMPING MAT AND SAFETY PADS ASSEMBLY













## Before Assembling

Please refer to the Parts List below for descriptions and reference numbers. The assembly steps use the "Description" and "ref #" to identify parts while assembling.

Make sure you have all parts listed in the table below. To check if you have all required parts for your net assembly, please refer to page 27 (for 7x10ft & 8x12ft), page 33 (for 9x14ft), page 40 (for 10x17ft), and page 47 (for 14x16ft). If you think you're missing any parts, please contact your supplier.

### Parts List (Excluding the Net Assembly)

### Select your Trampoline Size

| Ref # | Item Image  | Description  | 7x10'          | 8x12'          | 9x14'          | 10x17'         | 14x16'                 |
|-------|---|--|----------------|----------------|----------------|----------------|------------------------|
| 1a    |    | Short frame piece<br>(With leg sockets)  | 2<br>Curved    | 2<br>Straight  | -              | 2<br>Curved    | 2<br>Curved            |
| 1b    |    | Short frame piece<br>(Without Leg Sockets)   | -              | -              | 2<br>Curved    | -              | -                      |
| 2a    |    | Long frame piece<br>(With leg sockets)   | 2<br>Straight  | 2<br>Curved    | 2<br>Straight  | -              | 2<br>Curved            |
| 2b    |    | Long frame piece<br>(Without Leg Sockets)  | -              | -              | -              | 2<br>Curved    | -                      |
| 3     |   | Frame connector<br>Note: some models may come with sockets   | -              | 4<br>Angled    | 4<br>Angled    | 4<br>Angled    | 4 Straight<br>4 Angled |
| 4     |  | Leg extension  | 8              | 8              | 8              | 8              | 8                      |
| 5     |  | Leg<br>("A" & "B" refers to where the net pole bolts or spring clips go into the holes in the legs, "A" & "B" holes are at different angles) | 2 x A<br>2 x B | 2 x A<br>2 x B | 2 x A<br>2 x B | 2 x A<br>2 x B | 2 x A<br>2 x B         |
| 6     |  | Frame corner piece<br>("A" & "B" orientation - similar concept to RHS & LHS)   | 2 x A<br>2 x B | 2 x A<br>2 x B | 2 x A<br>2 x B | 2 x A<br>2 x B | 2 x A<br>2 x B         |
| 7     |  | Jumping mat  | 1              | 1              | 1              | 1              | 1                      |
| 8     |  | Spring - Long<br>Spring - Short  | 68<br>-        | 88<br>-        | 94<br>-        | 92<br>4        | 110<br>4               |
| 9     |  | Spring tool  | 1              | 1              | 1              | 1              | 1                      |
| 10    |  | Safety pads & bungee cords   | 1              | 1              | 1              | 1              | 1                      |
| 11    |  | User manual  | 1              | 1              | 1              | 1              | 1                      |



**Warning:** Wear suitable gloves to prevent any injuries to your hands from pinch points during assembly (especially when handling any metal parts).

Minimum two people required to assemble this trampoline.



## Step 1 - Frame (All Sizes)

Lay out the steel frame parts as per layout diagrams on the following pages.

All the parts with the same ref # are interchangeable except please note:

### Frame Corners – All Sizes:

- The frame corner pieces (ref #6) have two different orientations (similar concept to RHS and LHS), simply place all frame parts with the “spring” locating holes to the top, please identify them before assembling. The corner frame pieces have also been marked with an “A” or “B” label to assist identifying the orientation and the matchup with the leg assemblies.

### Legs – 7x10, 8x12:

- The legs (ref #5) have holes pre-drilled to suit the net pole eye bolts. The leg assemblies need to be facing the right way in the right location for the net poles to be assembled correctly later. This means the leg bottom and leg extension holes must be in-line with the holes on the main frame leg socket when the legs are fully assembled. To help with the leg assembly’s orientation, they are marked with an “A” or “B” label. When setup correctly, the matching “A” labelled corner and leg pieces will be diagonally opposite the trampoline from each other. This will be the same for the “B” labelled pieces. Please refer to the frame layout diagrams on the next page.

### Legs – 9x14ft, 10x17ft, 14x16ft:

- The legs (ref #5) and the leg uprights (ref #4) have spring clips pre-installed at the male ends. The leg assemblies need to be facing the right way in the right location for the spring clips and matching holes to line up. This means the leg bottom and leg extension holes must be in-line with the holes on the main frame leg socket when the legs are fully assembled. To help with the leg assembly’s orientation, they are marked with an “A” or “B” label. When setup correctly, the matching “A” labelled corner and leg pieces will be diagonally opposite the trampoline from each other. This will be the same for the “B” labelled pieces. Please refer to the frame layout diagrams on the following relevant pages.

## Handy Tips (All Sizes)

### Assembly Tip:

- All steel joints can naturally move or rub a very small amount when under load (during trampoline use). While this small movement is normal, if the joints are dry, they can sometimes create unwanted noise (typically “squeaking”). The best way to prevent this is during frame assembly. You can apply a long-life steel joint lubricant, for example, an “anti-seize” paste or “general use grease” to each male end metal joint before fitting, this also makes it easier to disassemble the trampoline. **Note:** Avoid using spray lubricants such as “WD40” as they are a short-term lubricant and will quickly lose effectiveness.

### Assembly Tip:

- When assembling frame pieces align the connecting items and push fit by hand as much as possible, if you need some extra help, please use a rubber mallet (**do not** use a steel hammer as you can damage the frame). If the metal pieces aren’t joining easily, inspect the pieces for any metal burrs and remove if required or/and you can use a rubber mallet to tap it in place.

### 7x10ft Frame Layout

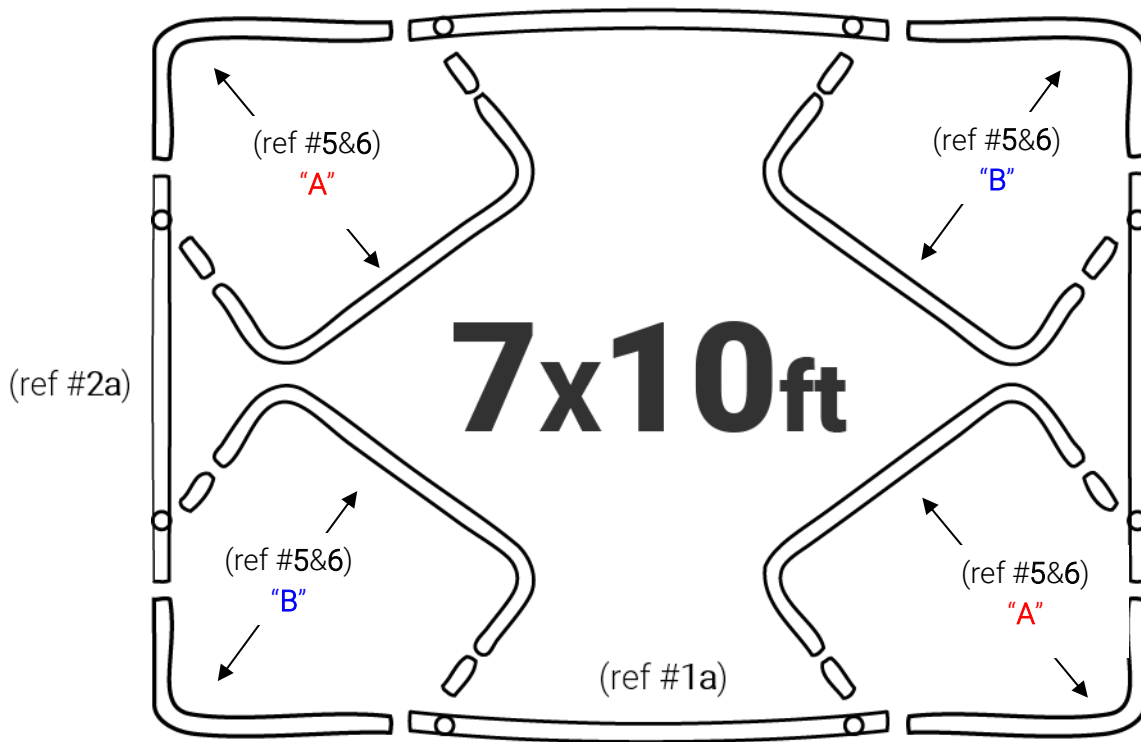

### 8x12ft Frame Layout

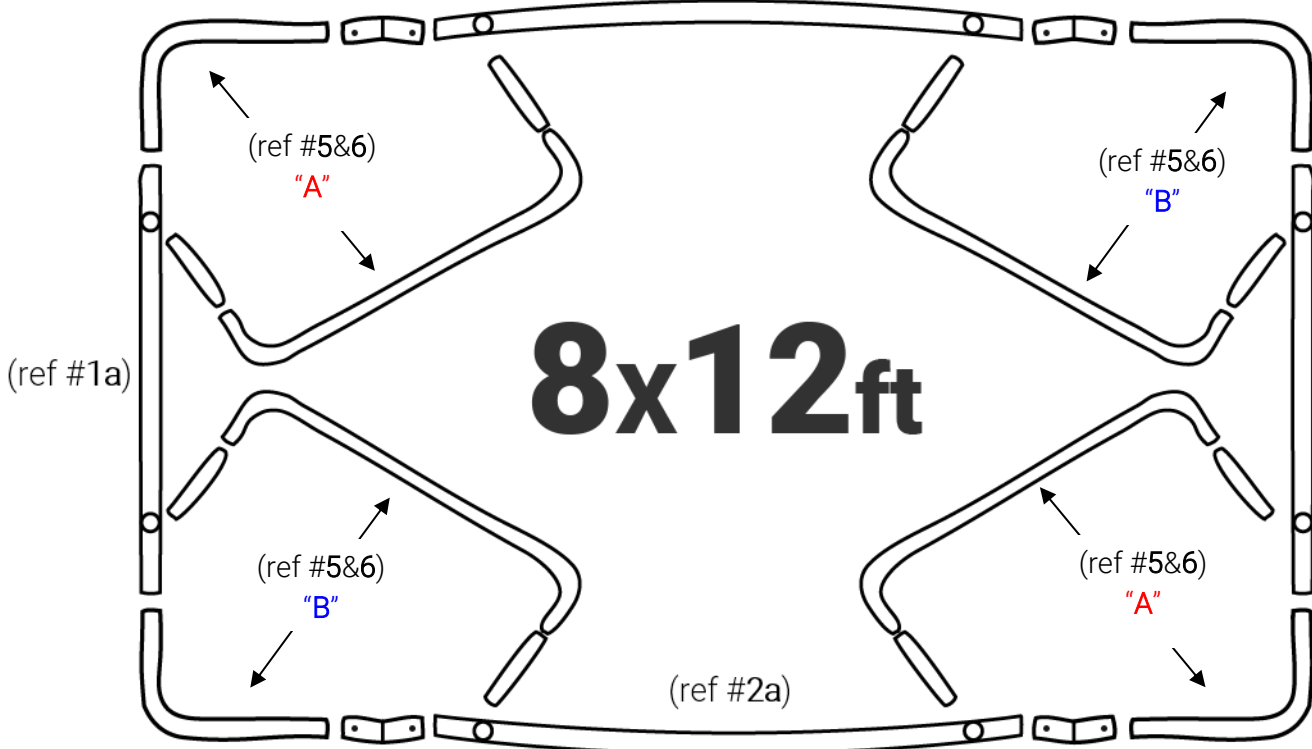

**9x14ft Frame Layout**

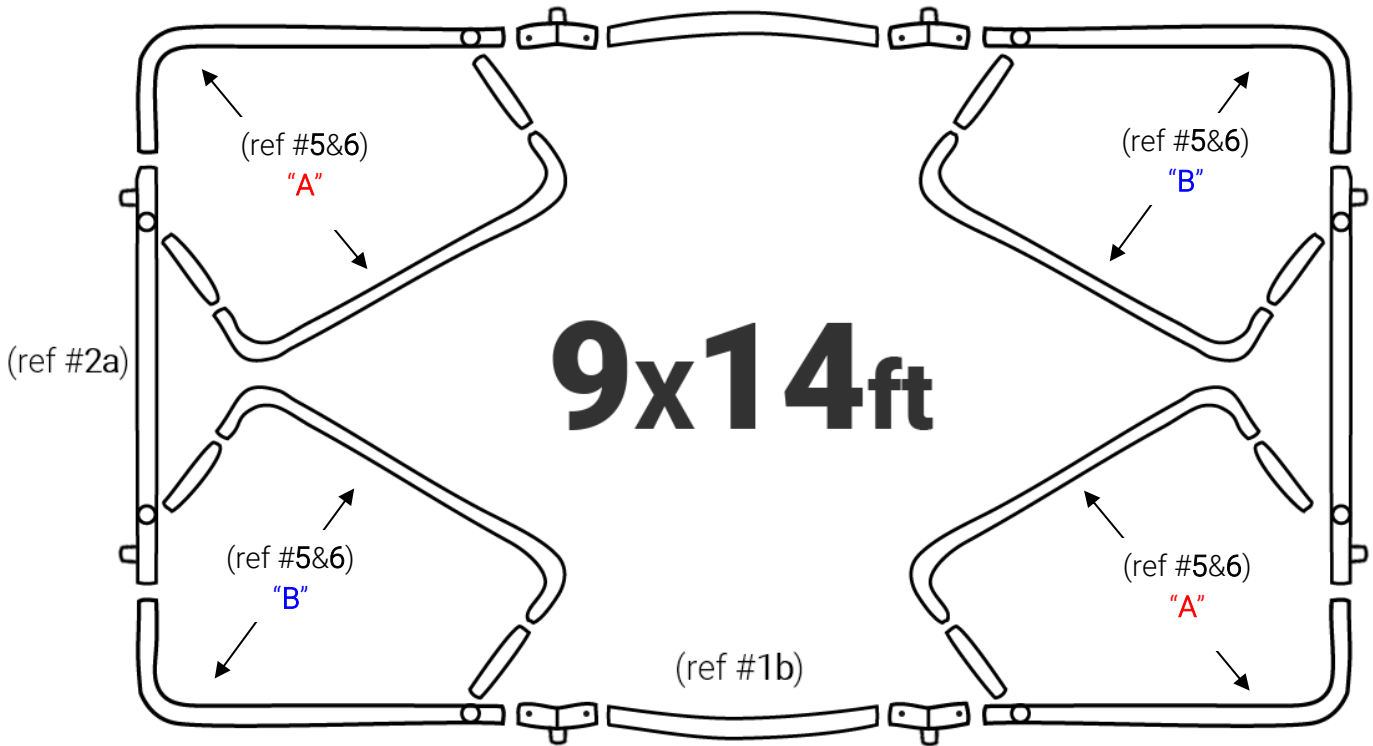

**10x17ft Frame Layout**

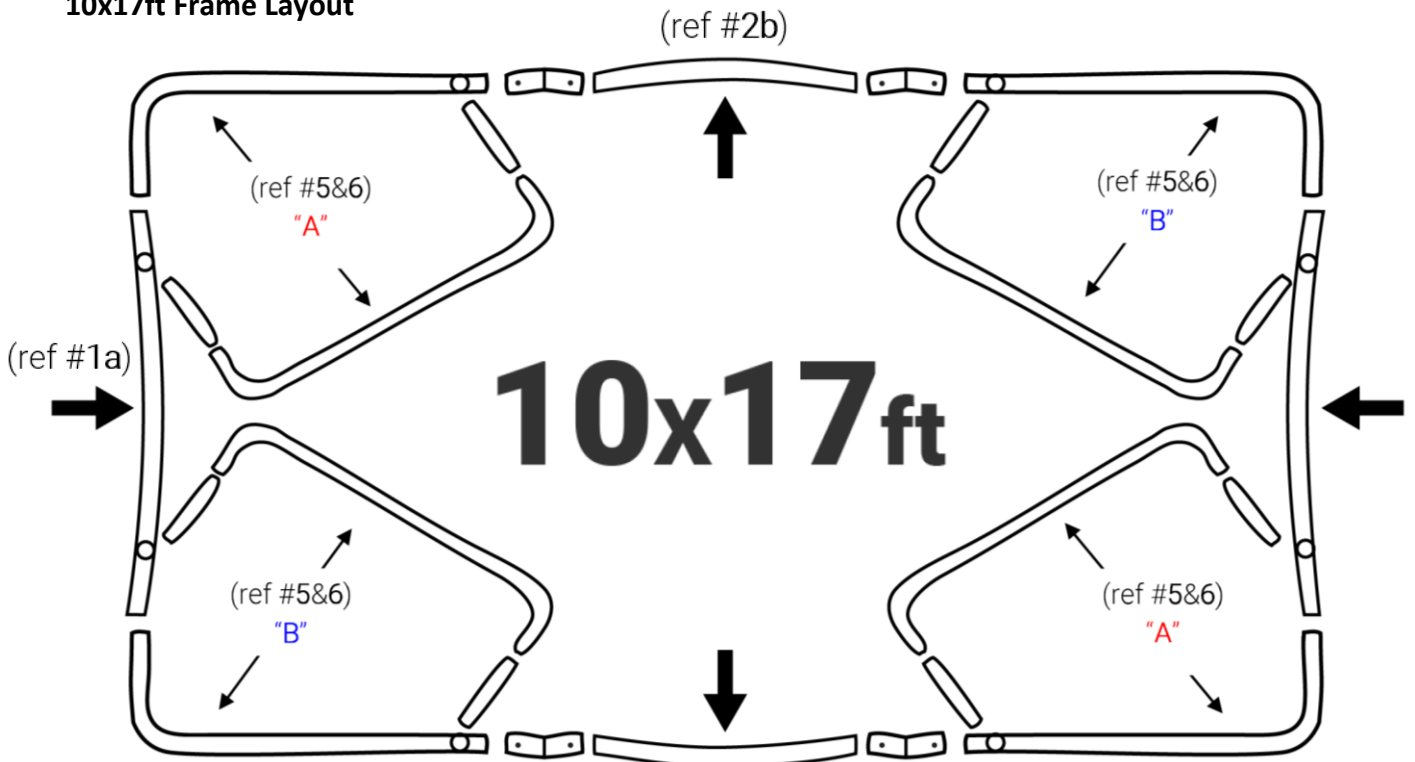

**10x17ft ONLY Note:** As shown by the larger arrows in the image above  
The rails on the short end of the trampoline curve inwards  
The rails on the long side of the trampoline curve outwards

14x16ft Frame Layout

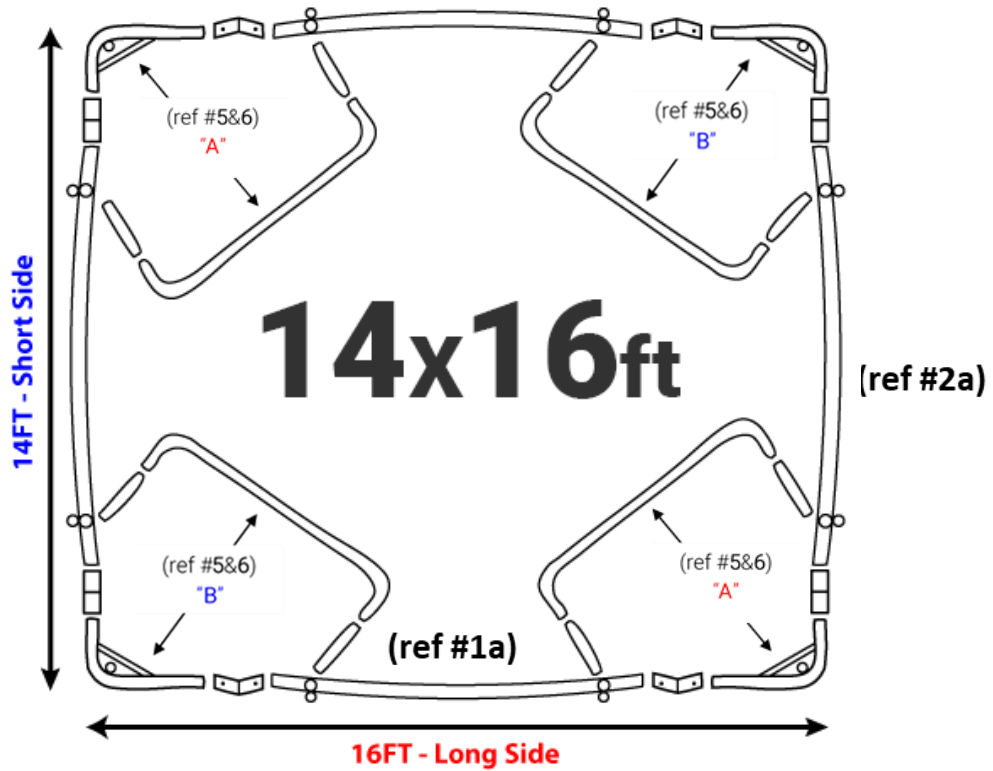

**Very Important Assembly Tip!**

The longer centre rail goes on the short side with the shorter corner section.  
 The shorter centre rail goes on the long side with the longer corner section.  
 Please look closely at the detail in the diagram below.

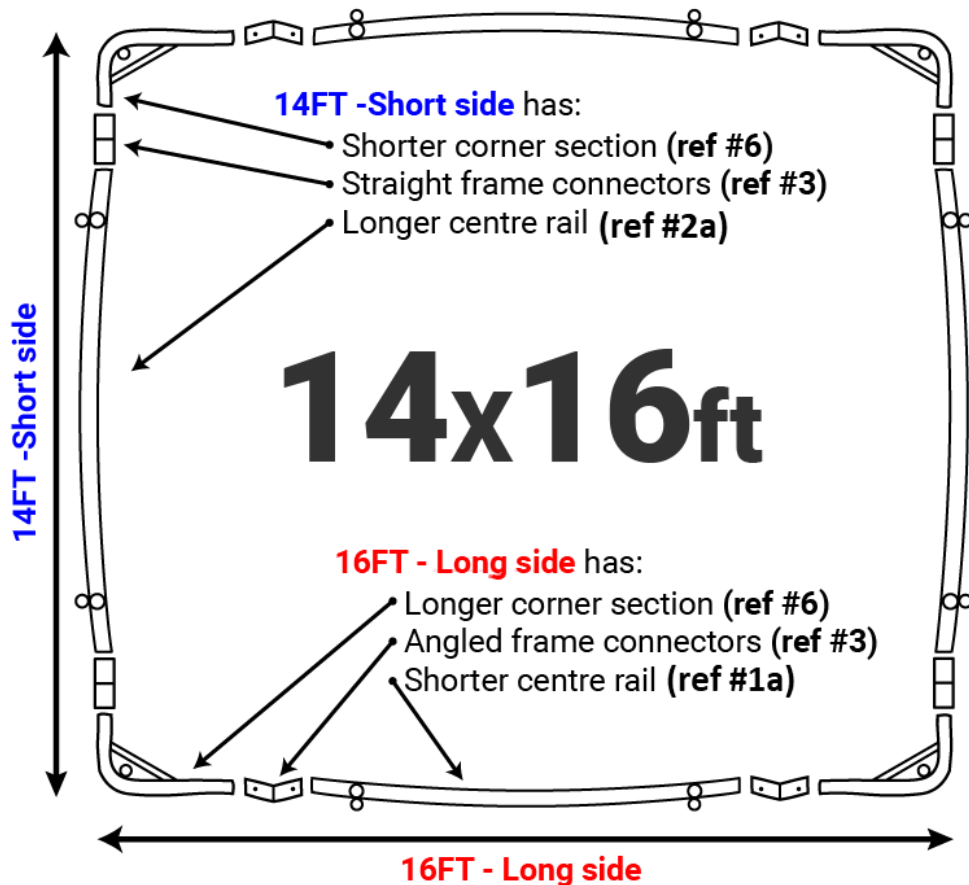



## Important Frame Assembly Notes



Our rectangle trampolines have an engineered 'Power Curve Frame'. This design gives extra bounce and strength. The jumping stresses that flow back to the frame are considerable, especially on the long side of a rectangle trampoline. This has been allowed for in the design and configuration, so it's important to assemble the frame correctly. You will notice that when the frame is assembled the long side will have a noticeable curve, however, when the mat is installed and under full spring tension this will straighten up.

**Note:** For the 8x12ft, 9x14ft, 10x17ft, and 14x16ft:

Install the frame connectors on the long side of your trampoline as shown in the diagram below.

**Note:** For the 14x16ft only:

There are **four straight frame connectors** (ref #3), these go on the short (14ft) side and there are also **four angled frame connectors** (ref #3), these go on the long (16ft) side as shown on page 14.

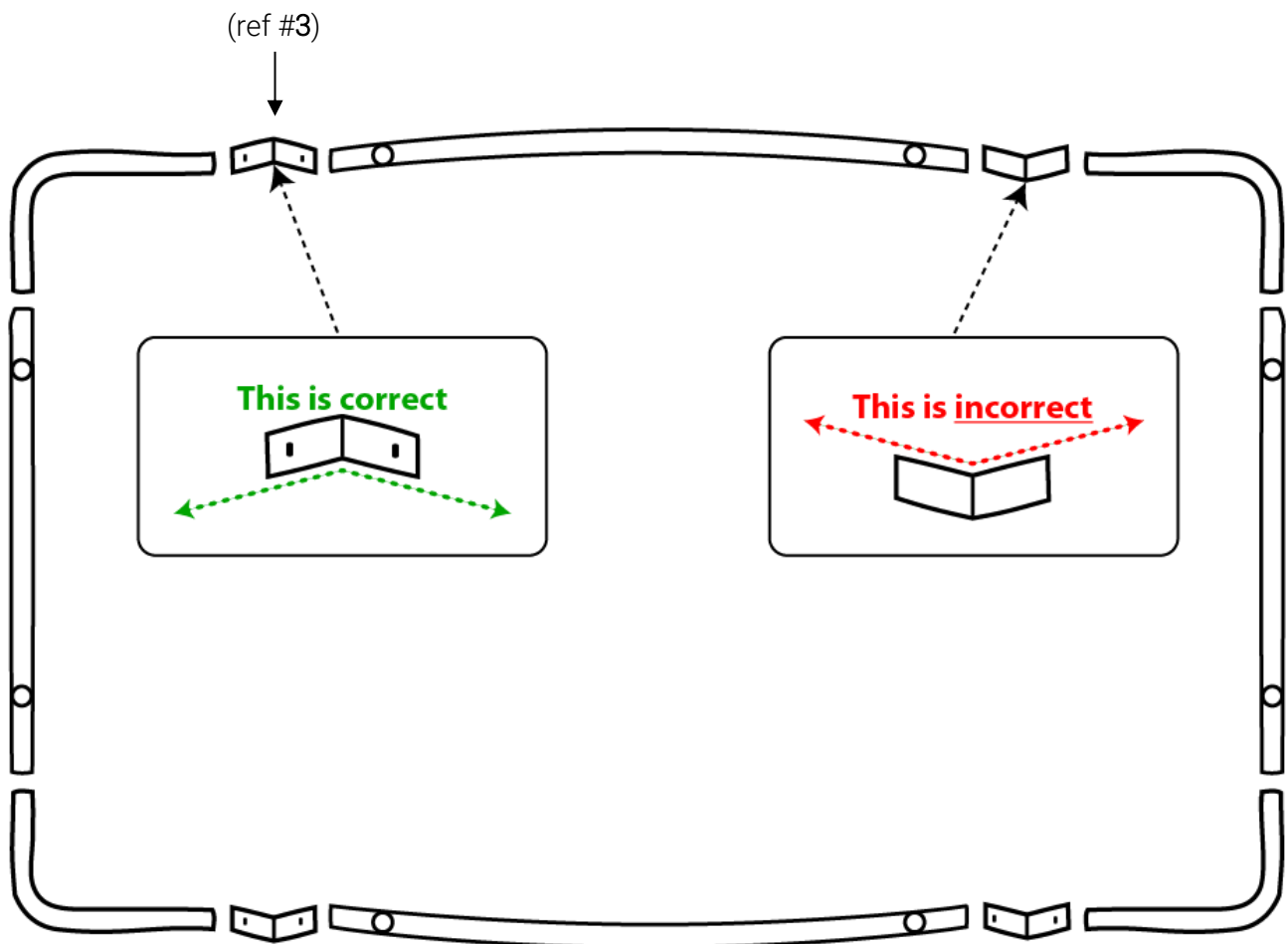

## Step 2 - Leg (All Sizes)

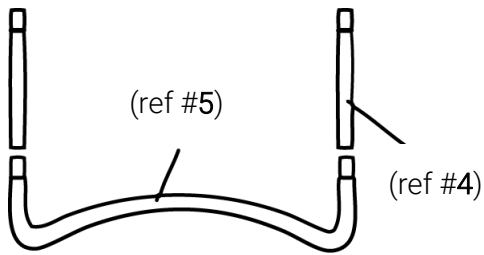

Slide all the leg extensions (ref #4) onto the legs (ref #5).

## Step 3 - Frame (7x10ft & 8x12ft)

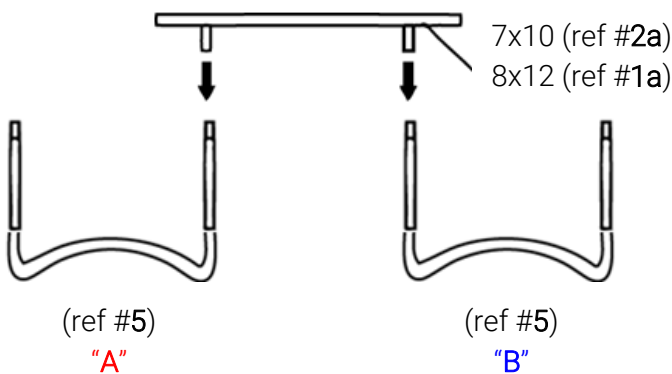

Two people will be necessary at this point. One person lifts the leg assembly from **step 2** to a standing position and inserts the top of one of the leg extensions (ref #4) into the corresponding frame with leg sockets. Repeat this with another support assembly from **step 2**. You should now have two leg assemblies held together by one top frame with socket (7x10 ref #2a, 8x12 ref #1a).

Repeat this with all leg assemblies.

### Important!

Be aware of the type "A" & "B" legs and frame corners. "A" legs have opposite hole angles compared to the "B" legs, this is so the net pole eye bolts will line up correctly later when installing the net assembly. When setup correctly, the matching "A" labelled corner and leg pieces will be diagonally opposite the trampoline from each other. This will be the same for the "B" labelled pieces. You should now have the frame assembly as per the following diagram.

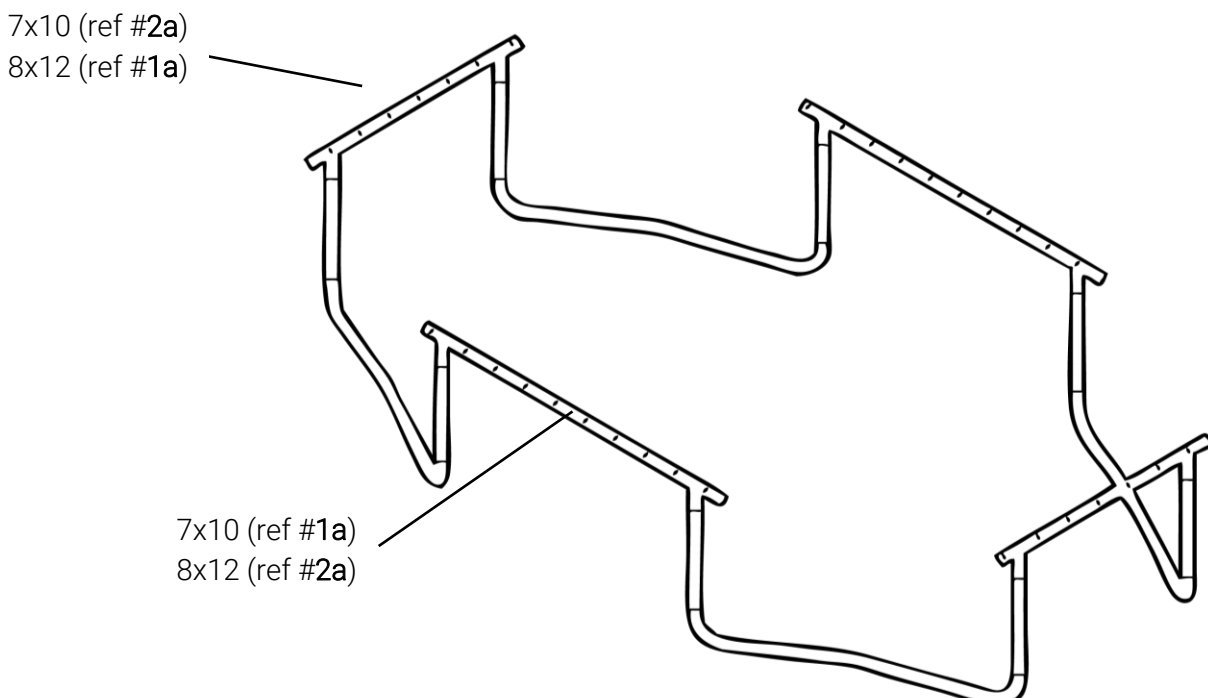



**7x10ft**

Install each frame corner piece (ref #6) as shown.

**8x12ft**

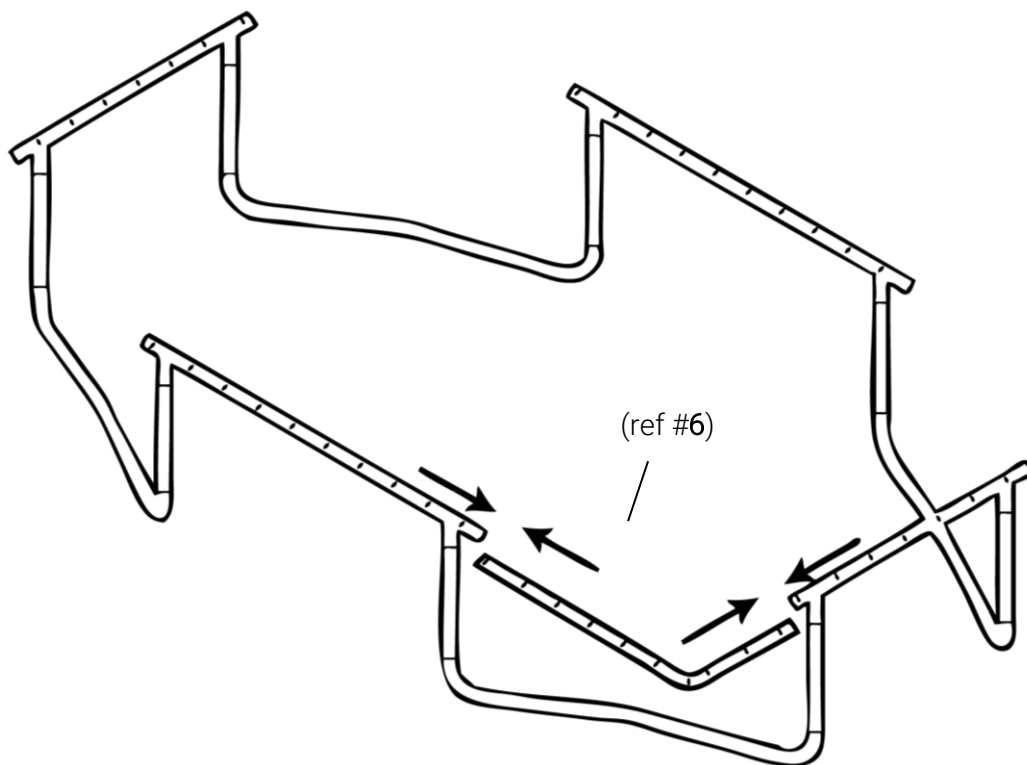

Install each frame connector (ref #3) then each frame corner piece (ref #6) as shown.

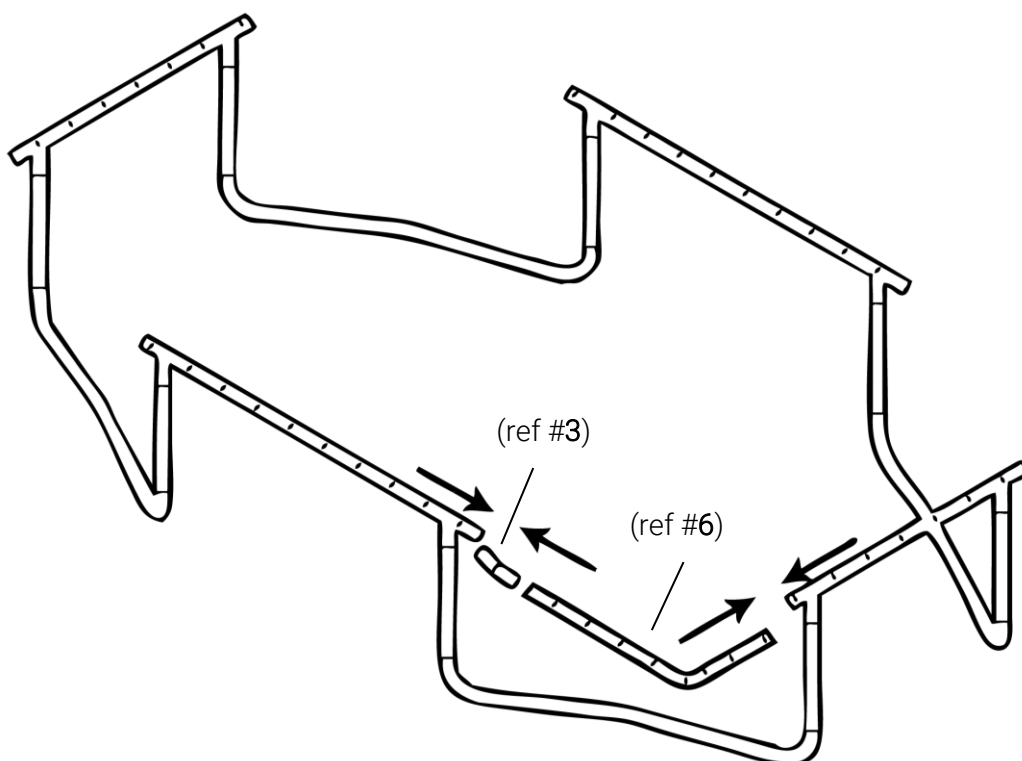

### 7x10ft

Once all of the frame corners (ref #6) are installed you will have a complete, free-standing frame.

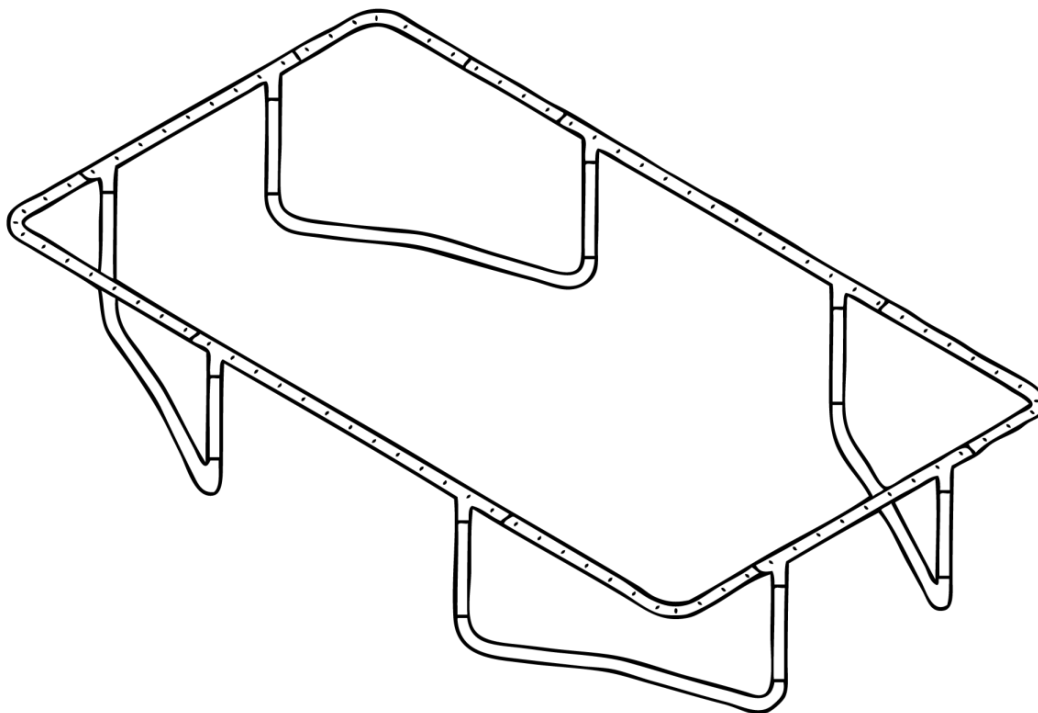

### 8x12ft

Once all of the frame corners (ref #6) and connectors (ref #3) are installed you will have a complete, free-standing frame.

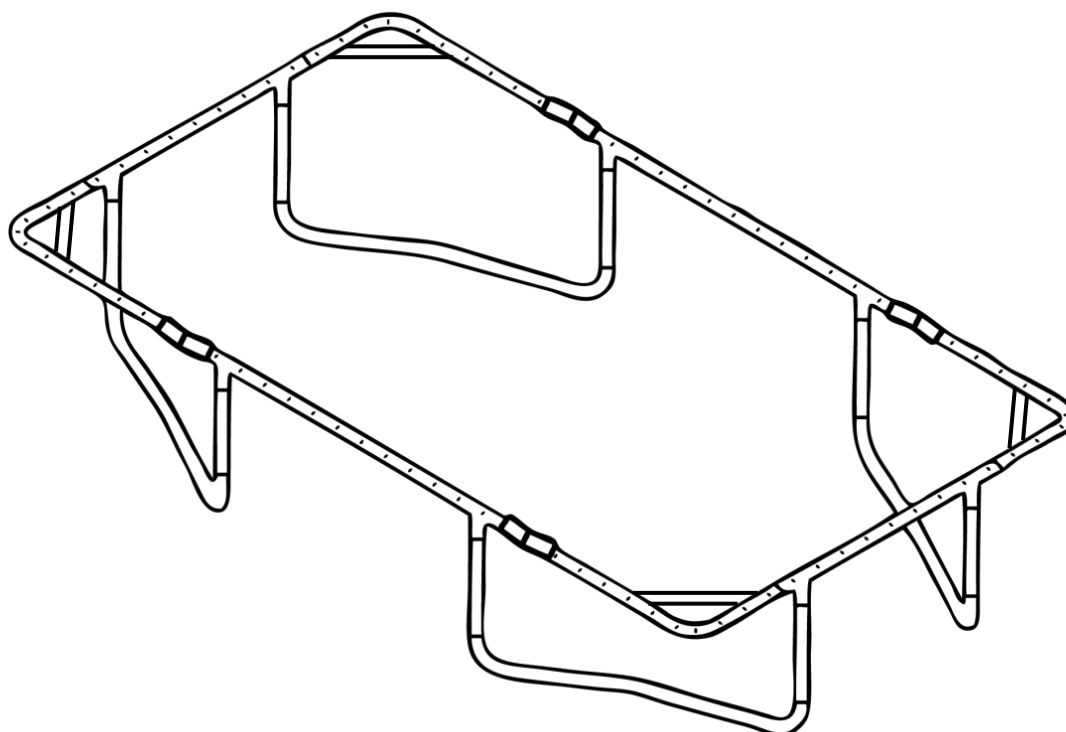

### Step 3 - Frame (9x14ft & 10x17ft)

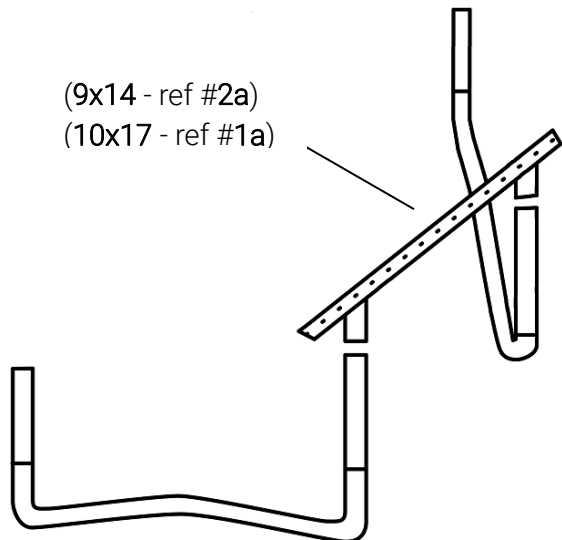

#### Step 3.1

One person holds the relevant frame rail piece with leg sockets (9x14 - ref #2a / 10x17 - ref #1a) while the 2<sup>nd</sup> person positions a leg support assembly (ref #5) to enable the top rail to be pushed down onto one leg extension. This is repeated with a 2<sup>nd</sup> leg support assembly.

#### Important Note:

The legs (ref #5) and the leg uprights (ref #4) have spring clips pre-installed at the male ends. The leg assemblies need to be facing the right way in the right location for the spring clips and matching holes to line up.

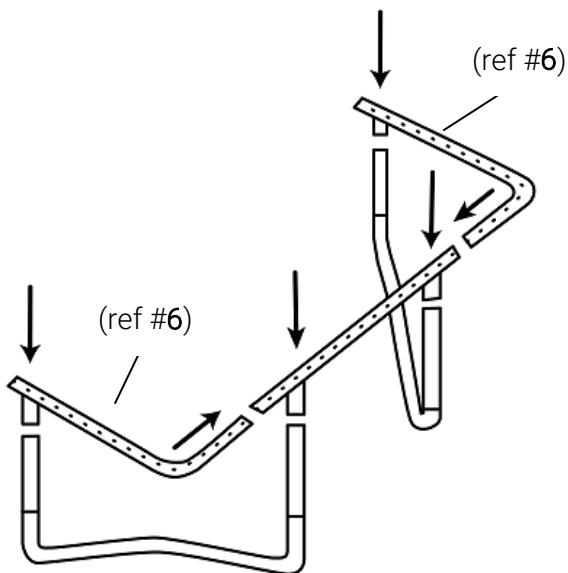

#### Step 3.2

Assemble the frame corners (ref #6).

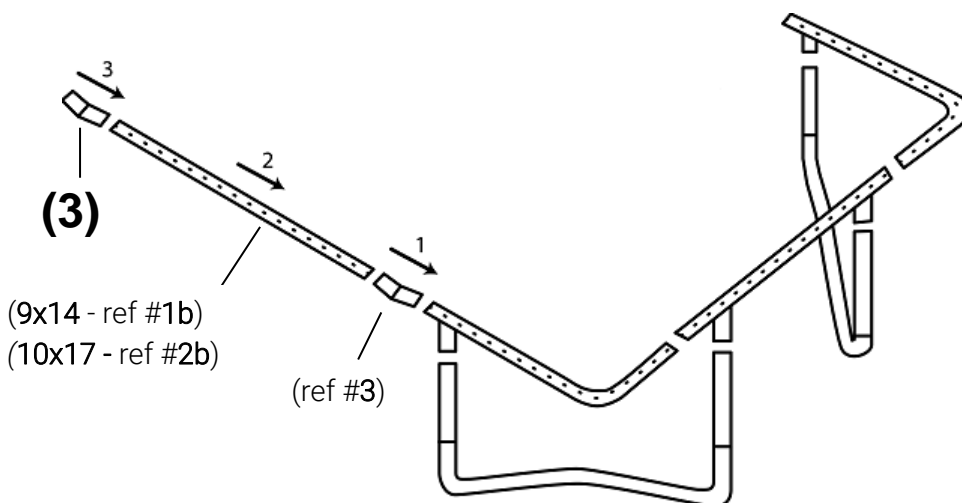

#### Step 3.3

Fit one frame connector (ref #3) and the relevant frame rail without leg sockets (9x14 - ref #1b / 10x17 - ref #2b) and then another frame connector (ref #3).

**Step 3.4**

Keep working on the frame by repeating steps 3.1 to 3.3 until the frame is completed.

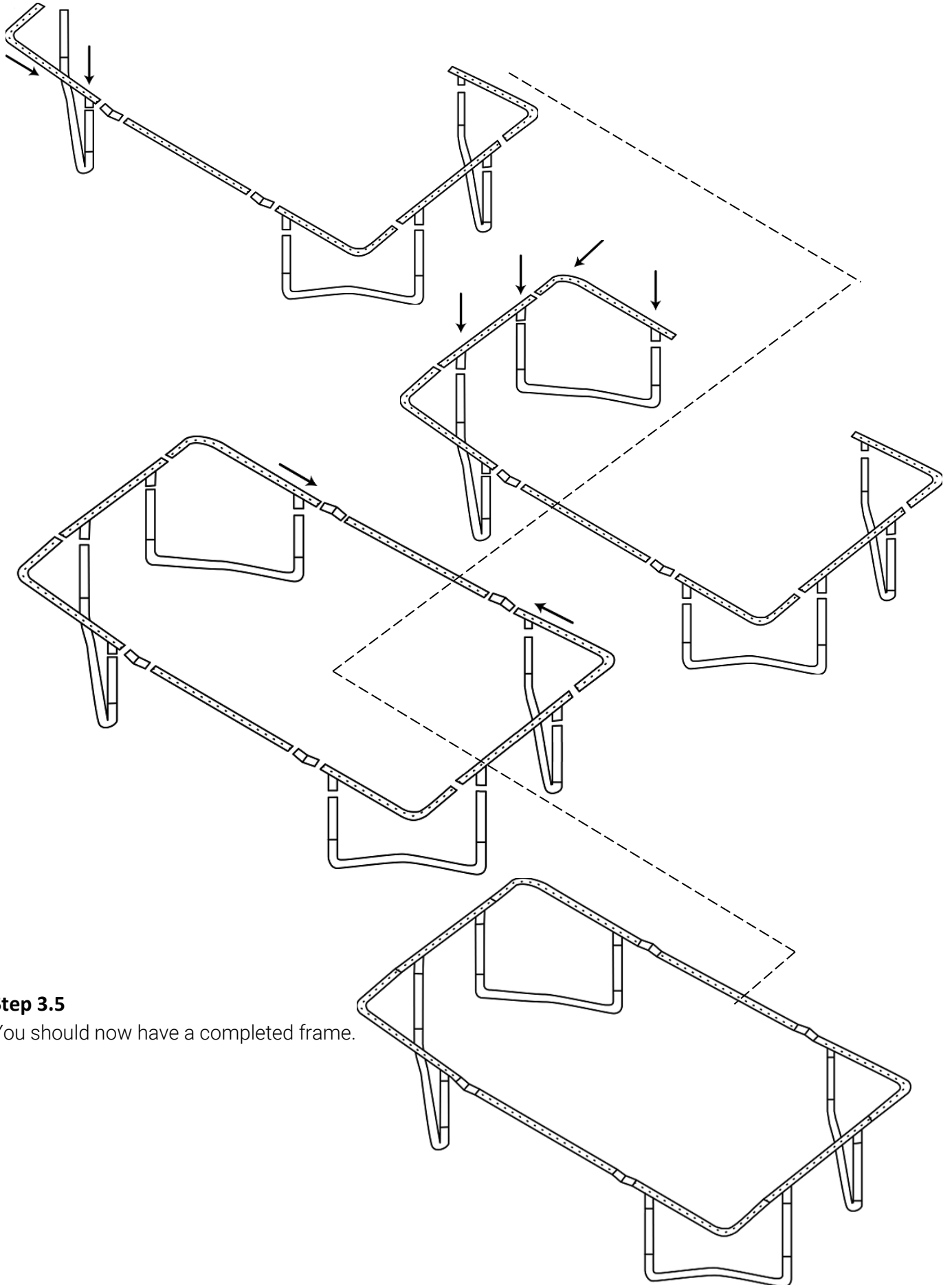

**Step 3.5**

You should now have a completed frame.

## Step 3 - Frame (14x16ft)

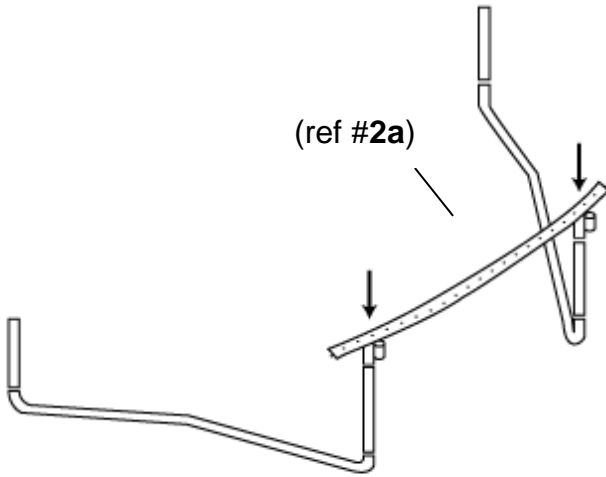

### Step 3.1

One person holds a frame rail (ref #2a) while the 2<sup>nd</sup> person positions a leg support assembly to enable the top rail to be pushed down onto one leg extension. This is repeated with a 2<sup>nd</sup> leg support assembly.

### Important Note:

The legs (ref #5) and the leg uprights (ref #4) have spring clips pre-installed at the male ends. The leg assemblies need to be facing the right way in the right location for the spring clips and matching holes to line up.

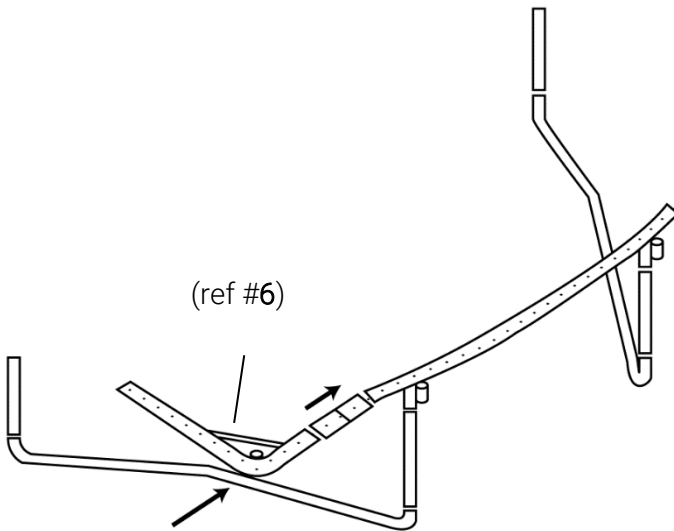

### Step 3.2

Assemble the frame corner (ref #6).

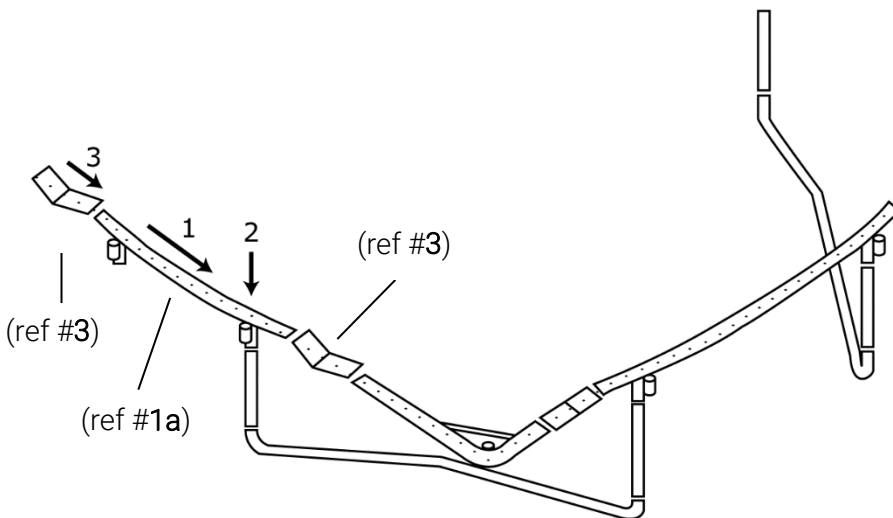

### Step 3.3

Fit one frame connector (ref #3) and a frame rail (ref #1a) and then another frame connector (ref #3).

**Note:** Refer to frame layout page for correct location of angled and straight frame connectors.

### Step 3.4

Keep working on the frame by repeating steps 3.1 to 3.3 until the frame is completed.

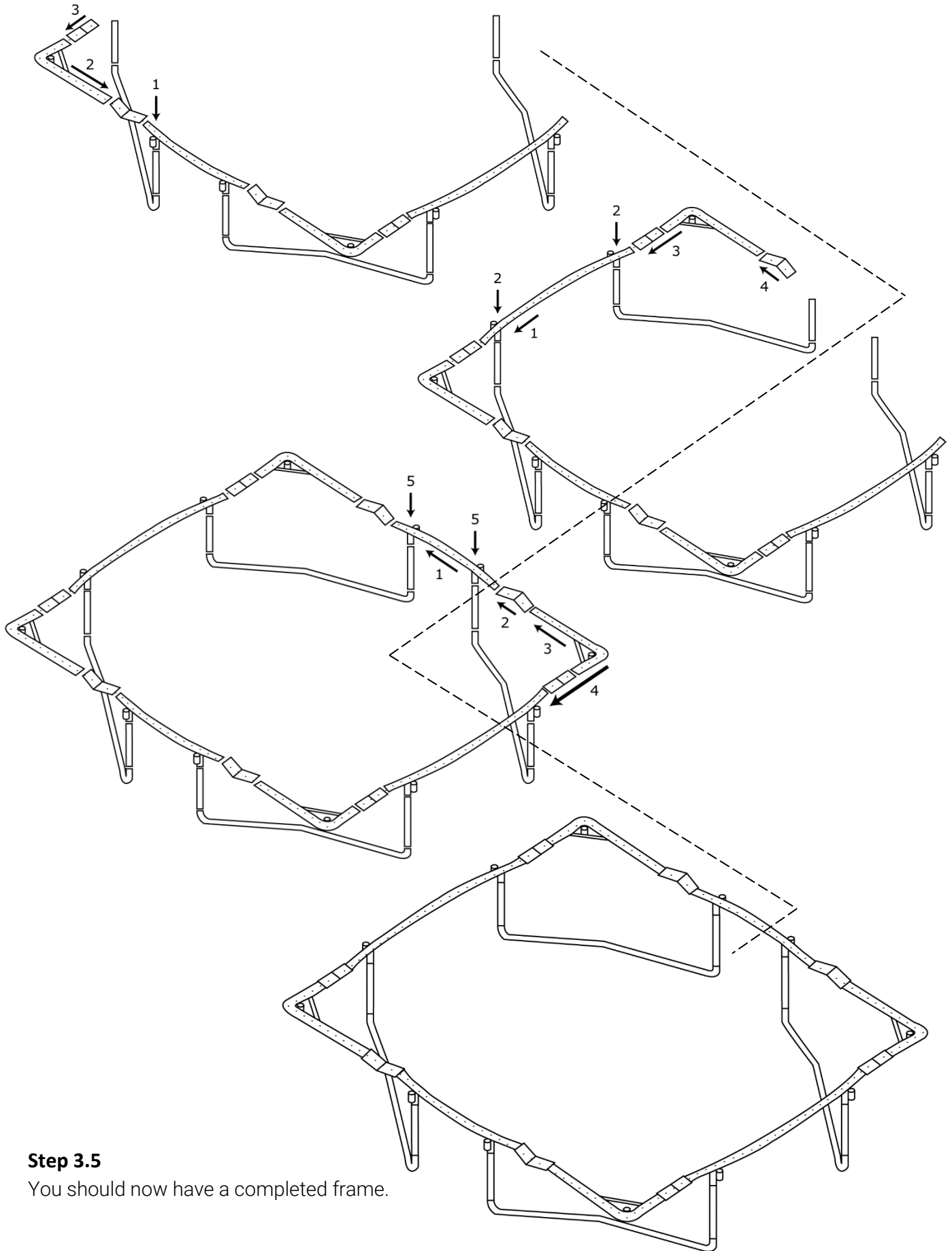

### Step 3.5

You should now have a completed frame.

## Step 4 - How to Use the Spring Tool (All Sizes)

**Warning:** Before attaching any springs, read these instructions.

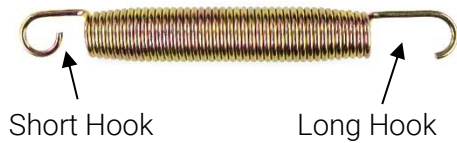

### Step 4.1

Identify the “short hook” and “long hook” ends of the spring.



### Step 4.2

Position the spring “short hook” into the corresponding mat V-ring, then use the spring tool and hook the “long hook” with the end of the spring tool.



### Step 4.3

Pull the spring tool until the spring is attached to the frame hole, then disengage the spring tool leaving the spring in the assembled position.

**Warning:** Please take care where your hands and other parts of the body are placed when pulling springs. Be aware that you are placing stored energy into the spring and if the spring is not restrained correctly it can cause injury to you or anyone else in the vicinity.

## Step 5 - Jumping Mat & Safety Pad with Protection Barrier (All Sizes)

**Warning:** Before attaching any springs read "How to Use the Spring Tool" instructions in step 4.

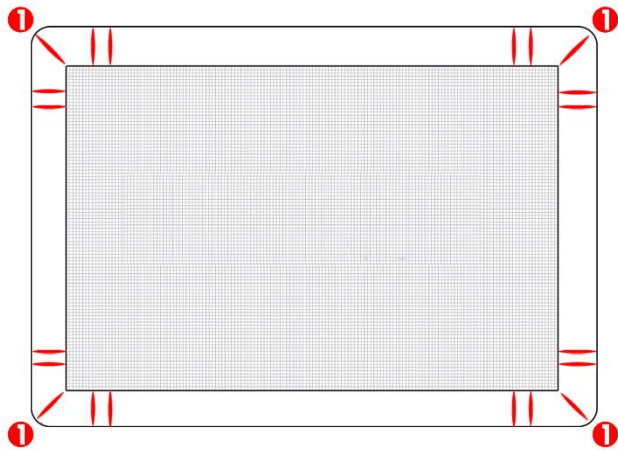

### Step 5.1

Lay out the jumping mat (ref #7) inside the frame, then attach the corner area springs as per diagram to the left.

**Note:** 1 all trampoline sizes (except the 7x10) have a spring fitted diagonally in the very corner. For the 8x12 and 9x14 all springs including the corner spring are the same size. For the 10x17 and 14x16 this corner spring is shorter than the rest of the spring set. (refer Parts list "Spring - Short, qty 4").

When installing springs, be mindful to keep the tension on the mat balanced. Do this by installing the next spring on the opposite side of the frame. Then follow the sequence shown for assembling the rest of the springs.

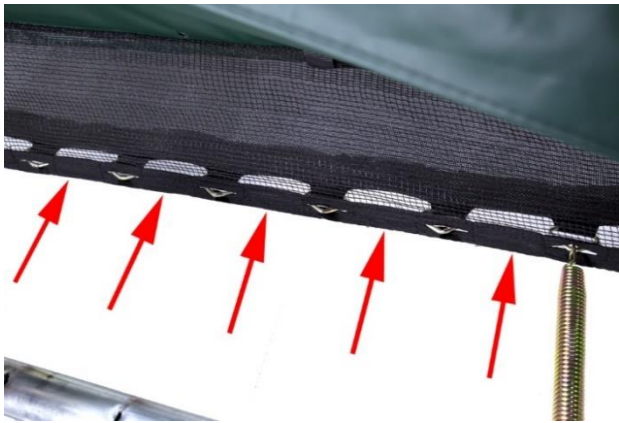

### Step 5.2

Now the jumping mat is under tension by the corner springs you now have a platform that can hold the pads. Lay your safety pads out on top of the mat. Underneath the pads, there's a protection barrier. For the time being ignore fitting this to the first springs already installed however allow enough slits for later. Start installing the protection barrier during all remaining springs being fitted. Starting next to the previously installed springs, slide the material over each spring V rings as per the diagram to the left.

**Note:** There is no need to allow for a protection barrier slit for the very corner diagonal spring, it is not required for this position.



### Step 5.3

Slide the material over each spring V-ring.

The initial corner springs then need to be removed and re-installed with the safety pad barrier in mind.



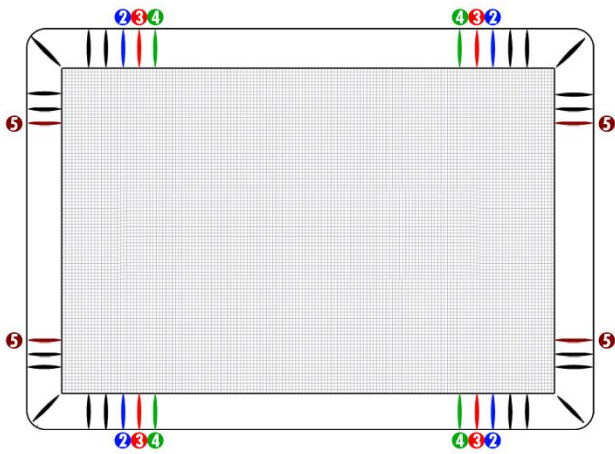

#### Step 5.4

Continue to slide the safety pad's protection barrier material over each spring V-ring and then attach the corresponding spring. **Continue this for steps 5.5, 5.6, and 5.7.**

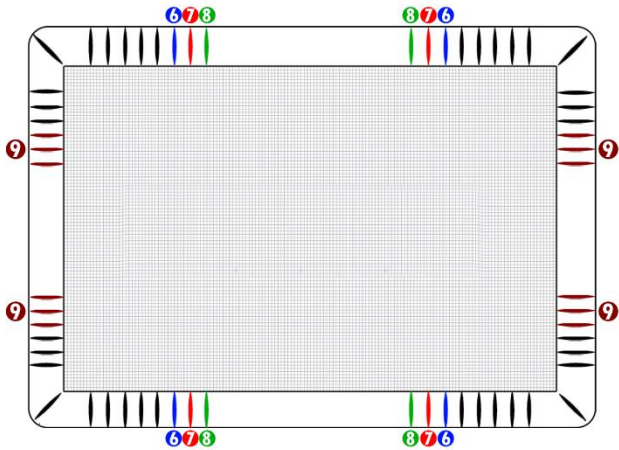

#### Step 5.5

Continue to slide the safety pad's protection barrier material over each spring V-ring and then attach the corresponding spring.

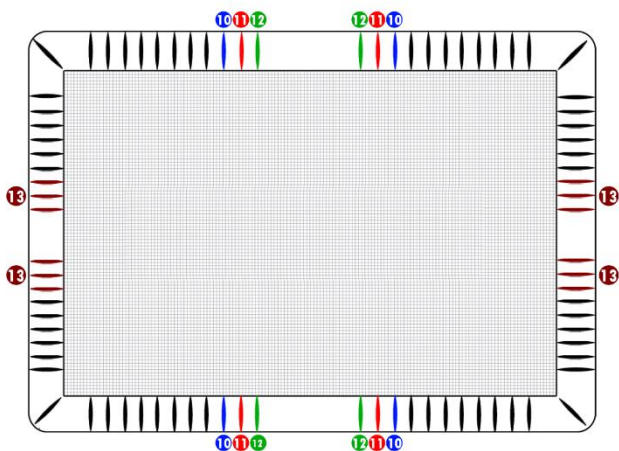

#### Step 5.6

Continue to slide the safety pad's protection barrier material over each spring V-ring and then attach the corresponding spring.

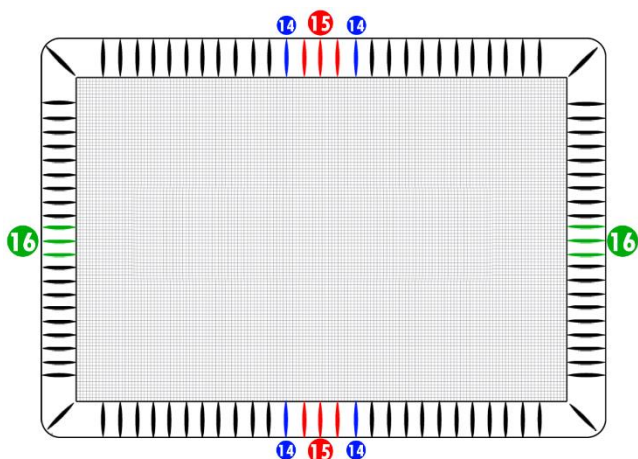

#### Step 5.7

Continue to slide the safety pad's protection barrier material over each spring V-ring and then attach the corresponding spring.

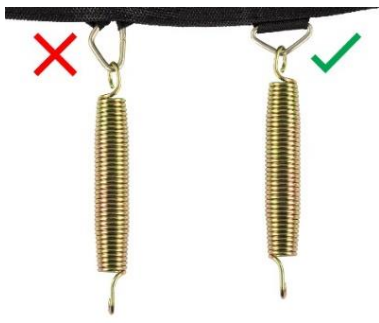

### Step 5.8

It's important to regularly check that all the jumping mat's V-rings are in the correct orientation. A V-ring can rotate in its hoop during assembly or when the user lands on the mat edge area. If the V-ring is left incorrectly rotated, the mat edge components will have uneven loads shortening the life of the mat and springs.



### Step 5.9

Now the jumping mat and the safety pad's protection barrier are fully secured you may now secure the safety pads to the jumping mat and frame with the included bungee cords.

Thread the bungee through the pad underside black hoop. Work the head of the bungee cord so it aligns in-between the two spring V rings. Complete all pad inner attachment points



### Step 5.10

Lift the outside of the safety pads and locate the brass eyelets. Pinch the eyelet area so the eyelet holes line up. The bungee cord can then be threaded through.



### Step 5.11

Once the bungee cord is through the brass eyelets, loop the bungee cord around the main frame as shown. Rotate it around, so it's repositioned so the head is on the inside of the frame.

Repeat this step until all bungee cords are installed.

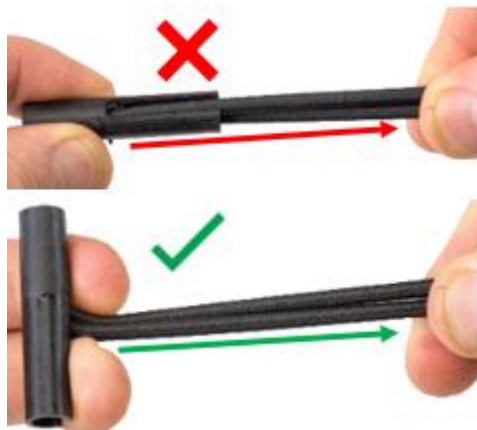

### Note:

The bungee head is held in by a fine lip inside the plastic toggle, so if pulled in line with a reasonable amount of force (as per the first image) then it's possible to pull the bungee right out, it can be refitted but it's better to avoid doing this in the first place. So, if stretching the bungee cord with a reasonable amount of force during installation it is better to pull with the head at right angle to the bungee cord (as shown in the second image).

**Note:** The safety integrity for the user is dependent on the safety pads remaining correctly positioned over the frame. It is strongly advised to check the position of the safety pads before using the trampoline each time.

The trampoline is now ready for the net enclosure to be assembled.

## Before Assembling the Safety Net Enclosure (All Sizes)



The net enclosure is an important safety device, ensure correct assembly. Minimum two people are required to assemble. Do not rush; some patience may be required.

## Entrance Location (All Sizes)

- 7x10ft, 8x12ft, 9x14ft, & 10x17ft: The entrance can only go on the **long side**.
- 14x16ft: The entrance can only go on the **short side**.

Note: Please refer to page 33 (for 9x14ft), page 40 (for 10x17ft), and page 47 (for 14x16ft).

## Step 6 - Attaching the Safety Net Enclosure (7x10ft & 8x12ft)

### Step 6.1

The net assembly items will be packed together, unpack and layout as above.

Remove the foams from the net poles as underlined in red below and sort by size as per the next step.



## Attaching the Safety Net Enclosure cont. (7x10ft & 8x12ft)

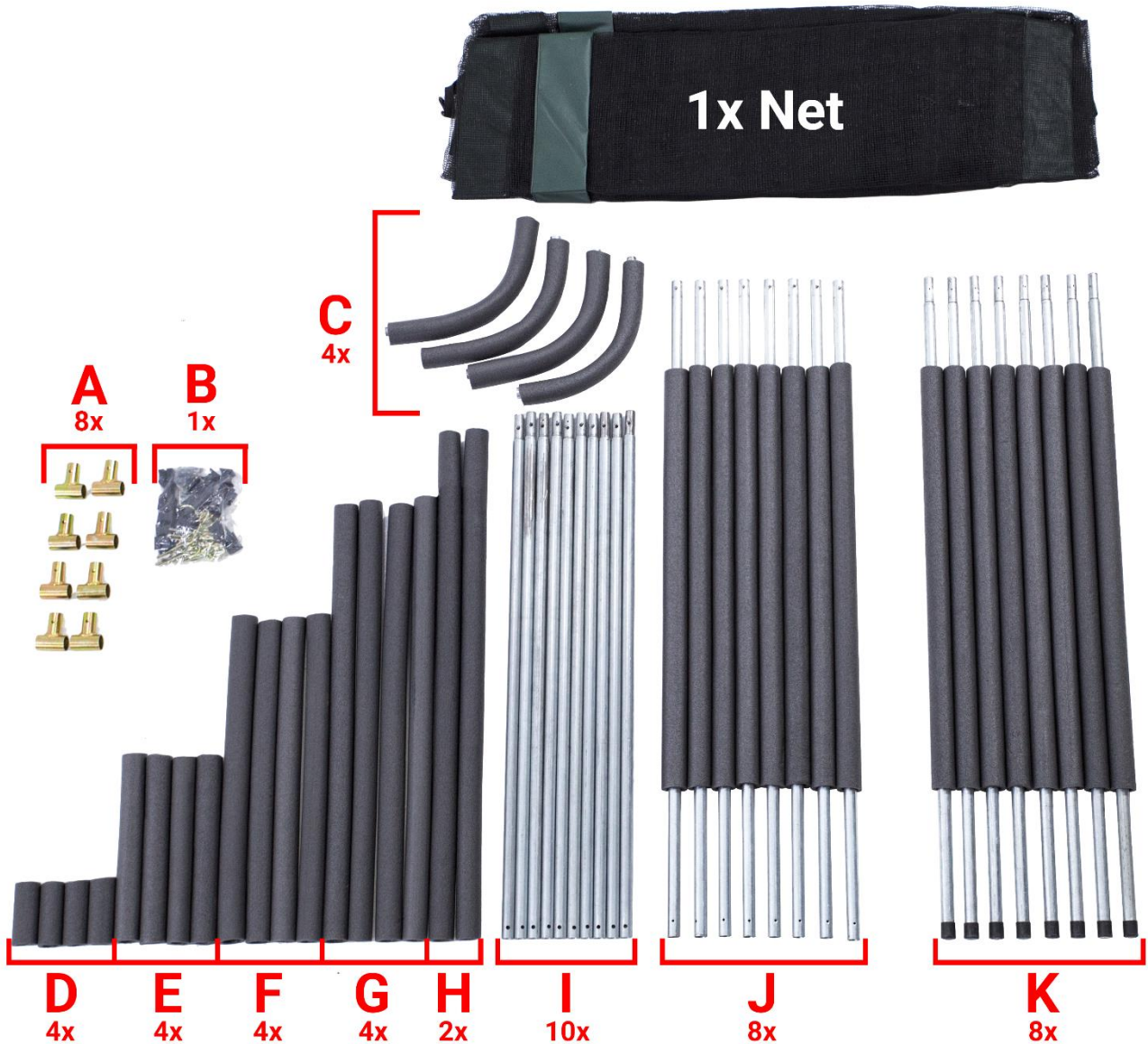

### Step 6.2

Please ensure that the box contains all the trampoline net enclosure parts listed above. The above image lists the quantity of each part that you should have. The items are now ready for assembly.

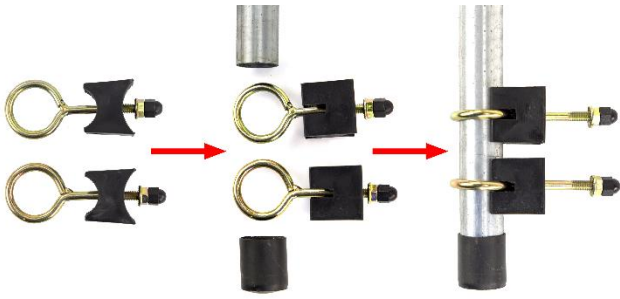

### Step 6.3 - (7x10 & 8x12 cont.)

Unpack the eye bolts (ref #B). Two eyebolt assemblies (ref #B) need to be fitted onto the bottom of each net pole piece (ref #K). To do this, you can temporarily slide the foam off the pole or take the end cap off the pole, replace after fitting both eye bolts.



### Step 6.4

Fix the top net poles to all the bottom net poles and ensure the spring clip securely engages at the net pole joint. You should now be able to stand the net pole assemblies upright.

### Step 6.5

Mount the net pole assembly to the trampoline by aligning the eye bolts with the bolt holes in the frame upright assembly. Position both eye bolts through the frame uprights. The top eye bolt will go through the upper frame T-connector, and the lower eyebolt will go through the vertical leg. At this stage, loosely tighten up the eye bolt locknut, this will be tightened further later. This allows the pole to move a small amount making the fitment of the net enclosure easier.



The trampoline will now look like this.



**Step 6.6 - (7x10 & 8x12 cont.)**

Lay the net on the trampoline and position the entrance on the **long** side of the trampoline. Start at the top and work the sleeves down the net poles and over the pole foams.

**Note:** The vertical pole sleeves will go to the outside (netting on the inside).

**Note:** Work from within the trampoline (remove shoes), take care not to fall.



**Step 6.7**

From the top of the net poles keep working your way around the trampoline and gradually pull the sleeves down (approximately 100 to 250mm at a time) until all net sleeves are fully down to the trampoline frame. Make sure the net pole foams are fully up to the top of the net pole sleeve.



**Step 6.8**

Install the T-pieces on the top of all net poles. Ensure the spring button is fully engaged.



**Step 6.9**

For the upper net rail assembly, either work from within the trampoline (remove shoes) or use a step ladder and work on the outside of the trampoline; either way, keep taking care not to fall.

Install all foams into their respective sleeves (excluding the corner sleeves).





### Step 6.10 - (7x10 & 8x12 cont.)

Start the top net rail assembly here.



Install an upper net rail (ref # 1).

**Note:** All the upper net rail pieces have a male and a female end to join to the next piece. It doesn't matter which way you start but once started keep orientating the ends the same way as you work around the top perimeter. A good method to avoid mixing up ends is to only work on one rail piece at a time and keep joining to the last piece you installed.



Once installed into foam/sleeve line up the rail with the tee-piece.

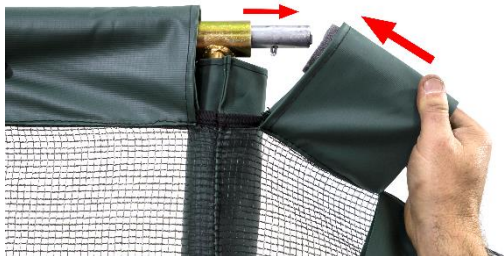

Slide through the T-piece.



Install through the next section of foam/sleeving.



The next step is to install the rail into the area circled.



### Step 6.11 - (7x10 & 8x12 cont.)

Install the next net rail through the sleeve.



### Step 6.12

Repeat the process for the next rail until you come to the corner section.



### Step 6.13

Install the corner piece and all the remaining upper net rail pieces.

**Note:** It is easier to install the corner pieces as one unit (foam pre-installed on the corner piece).



### Step 6.14

The net straps will be dangling at the bottom. Using the net clips at the end of the straps. Fasten the net to the corresponding V-ring on the mat by going under the padding from the outside of the frame.



### Step 6.15

Now that the net is fully assembled tighten all the eye bolt assembly nuts with a small spanner or socket (tighten firmly, so the net pole is held with adequate clamp pressure, to avoid stripping threads do not over tighten).



Your trampoline is now fully assembled.

Please skip to the "Care and Maintenance Instructions".



## Step 6 - Attaching the Safety Net Enclosure (9x14ft)

### Step 6.1

Identify and familiarise yourself with the parts. Check the diagram below.



### Step 6.2

Lay out the upper frame parts on a clean, level area as per the diagram below.

**Note:** If you don't have enough free space next to the trampoline on the ground, you can assemble this net on top of the trampoline frame/safety pads.

**Caution:** Until all the poles are assembled the pole's ends are exposed with possibly sharp edges. If care is not taken these can damage the jumping mat or safety pads. So, if you're assembling the net on the trampoline, we recommend temporarily laying a heavy tarp or thick cardboard over the trampoline.

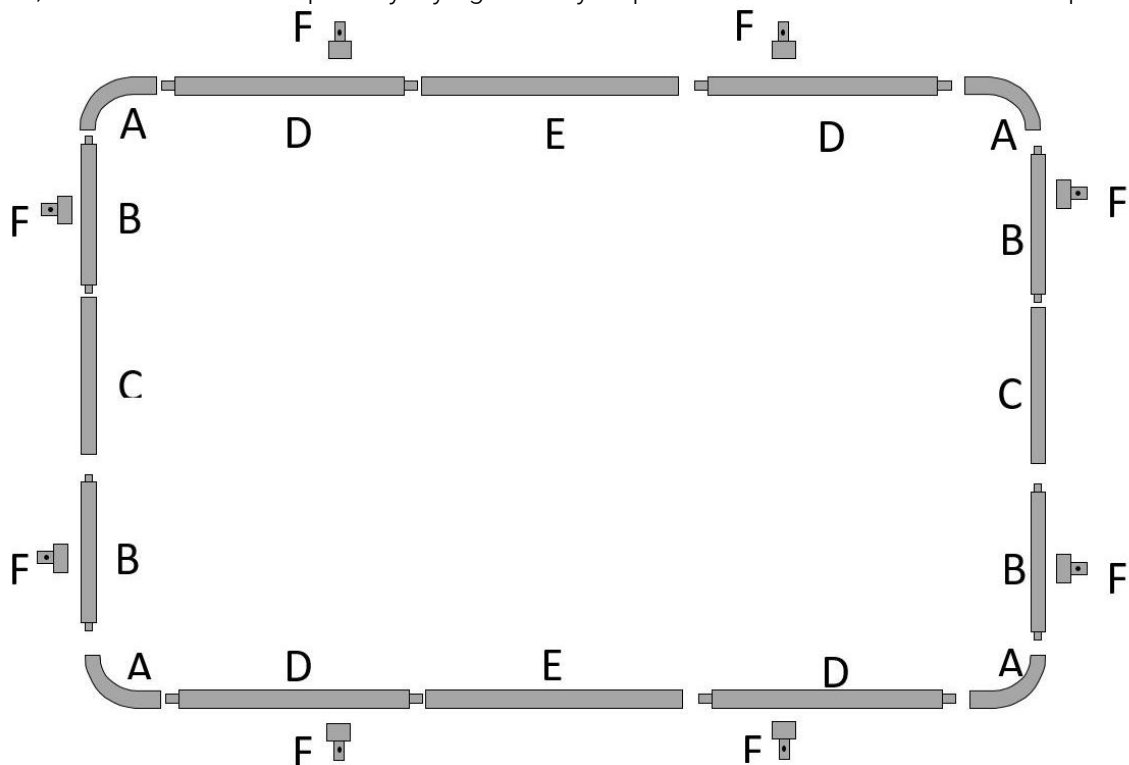

### Step 6.3 - (9x14 cont.)

Lay out the safety net with the entrance in the centre of the long side, so the upper net rails and foams line up with their respective net sleeves.

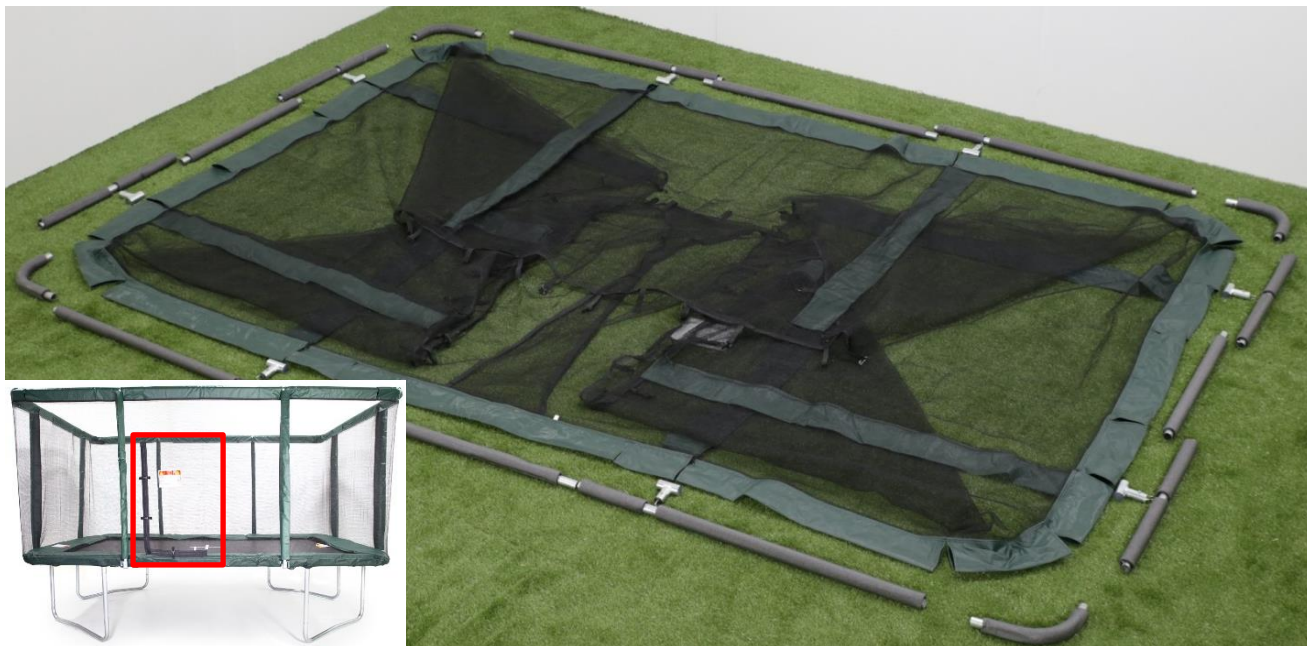

**Note:** The vertical pole sleeves will go to the outside (netting on the inside).

### Step 6.4

Starting at any corner, slide a corner piece (item "A") in the corresponding corner net sleeve with the **long side** of the corner piece (item "A") on the **long side** of the trampoline.



### Step 6.5 - (9x14 cont.)

The rail piece (item "B") has two foams slightly different in length; the short foam goes closer to the corner.

1. Remove the short foam from the upper net rail (item "B"). Insert the net rail bare end first (item "B") until the rail gets to the next sleeve as per image below.
2. Place T-piece (item "F") in-between the sleeve ends **with the spring clip facing to the top**.
3. Slide the rail (item "B") through the T-piece until it comes to the end of the next sleeve. Then, insert the foam (that was removed in step 1) in the sleeve over the bare end of the net rail.
4. Connect the rail piece (item "B") into the corner piece (item "A") (that was inserted in step 6.4) ensuring the spring clip 'clicks' into place.

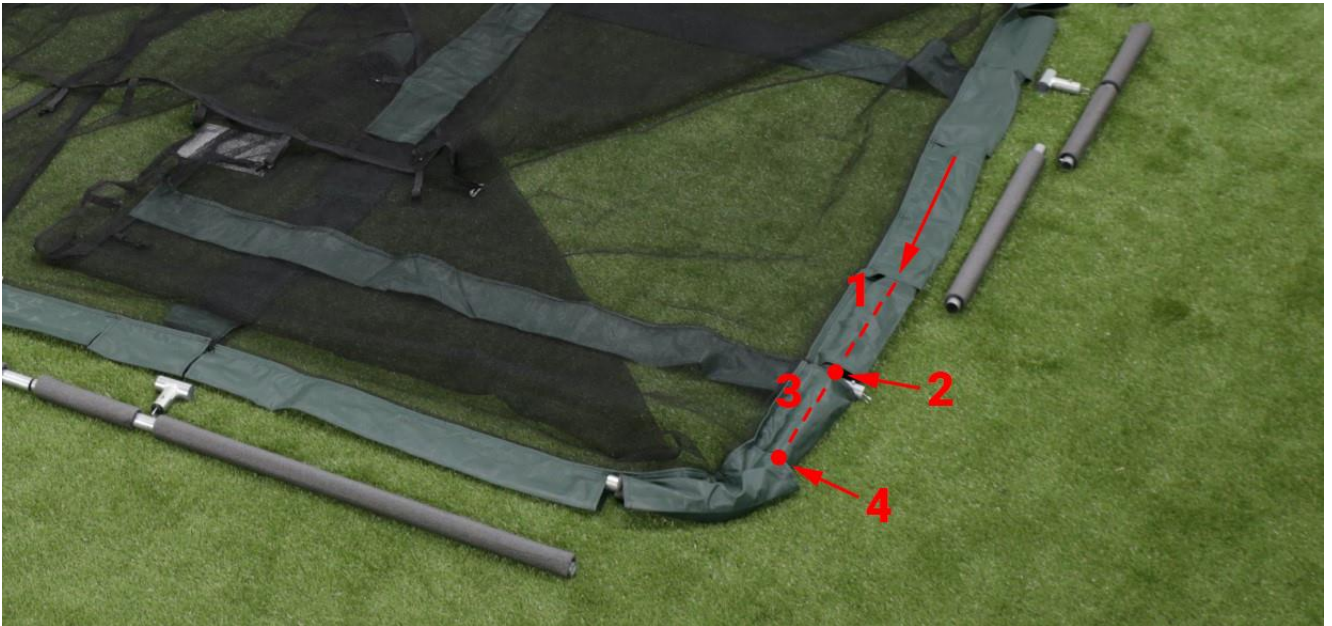

### Step 6.6

Insert the next rail piece (item "C") with its foam into the next sleeve.



### Step 6.7 - (9x14 cont.)

Continue this process all the way around the perimeter until all the rails are inserted with their foams into the net sleeves and all joints have their spring clips clicked into place.



**Note:** Double check you can see the spring clip facing up in all T-pieces, this is important later.

### Step 6.8

If you have worked at ground level, place the upper rail assembly onto the trampoline frame. Position the net sides to the outside of the trampoline as shown (at least two people required). Take care not to catch the netting material on any framework.

**Note:** For clarity, the trampoline's jumping mat & safety pads have been removed from the next two images.



### Step 6.9 - (9x14 cont.)

Connect the male vertical net pole (ref #1) with the female vertical net pole (ref #2) to make one vertical net pole assembly. Then, insert two of the vertical net pole assemblies into the vertical sleeves on one of the **long** sides. Make sure they join with the T-piece and the spring clip is clicked in.

**Note:** If you find the connecting the T-piece is an awkward height to reach, either use a step ladder or stand on the trampoline mat (remove shoes). Repeat process with the opposite side.

**Note:** It is handy if one person holds the upper net frame on the opposite side you are working on. This will prevent the upper rail structure from sliding off the trampoline while connecting the first two vertical poles to the upper T-pieces.



### Step 6.10

Lift one side of the top rail assembly and place the bottom of the vertical net poles into the square frame sockets and ensure the spring clip clicks in. Do the same on the opposite side.

**Note:** This is best done with 2 or more people.



**Step 6.11 - (9x14 cont.)**

Install the other four vertical net pole assemblies into their sleeves at both short ends of the trampoline, then, connect them into the tee-pieces at the top and the square frame sockets.



**Step 6.12**

Locate the net's elastic clips circled in blue and clip them onto the closest V-ring on the jumping mat's edge.



Once they're clipped on, it should look like this from underneath.



**Step 6.13**

1. Locate the net's elastic clips circled in red and then, clip them onto the closest frame side spring hook.



**9x14 cont.**

2. Cross the elastic straps, so the **left** strap at the bottom of the net pole will cross over and attach to the **right** frame end spring hook and vice versa.



3. Note: view from underneath pads.

**Step 6.14**

Your trampoline is now fully assembled. Please continue to read the rest of this manual.



## Step 6 - Attaching the Safety Net Enclosure (10x17ft)

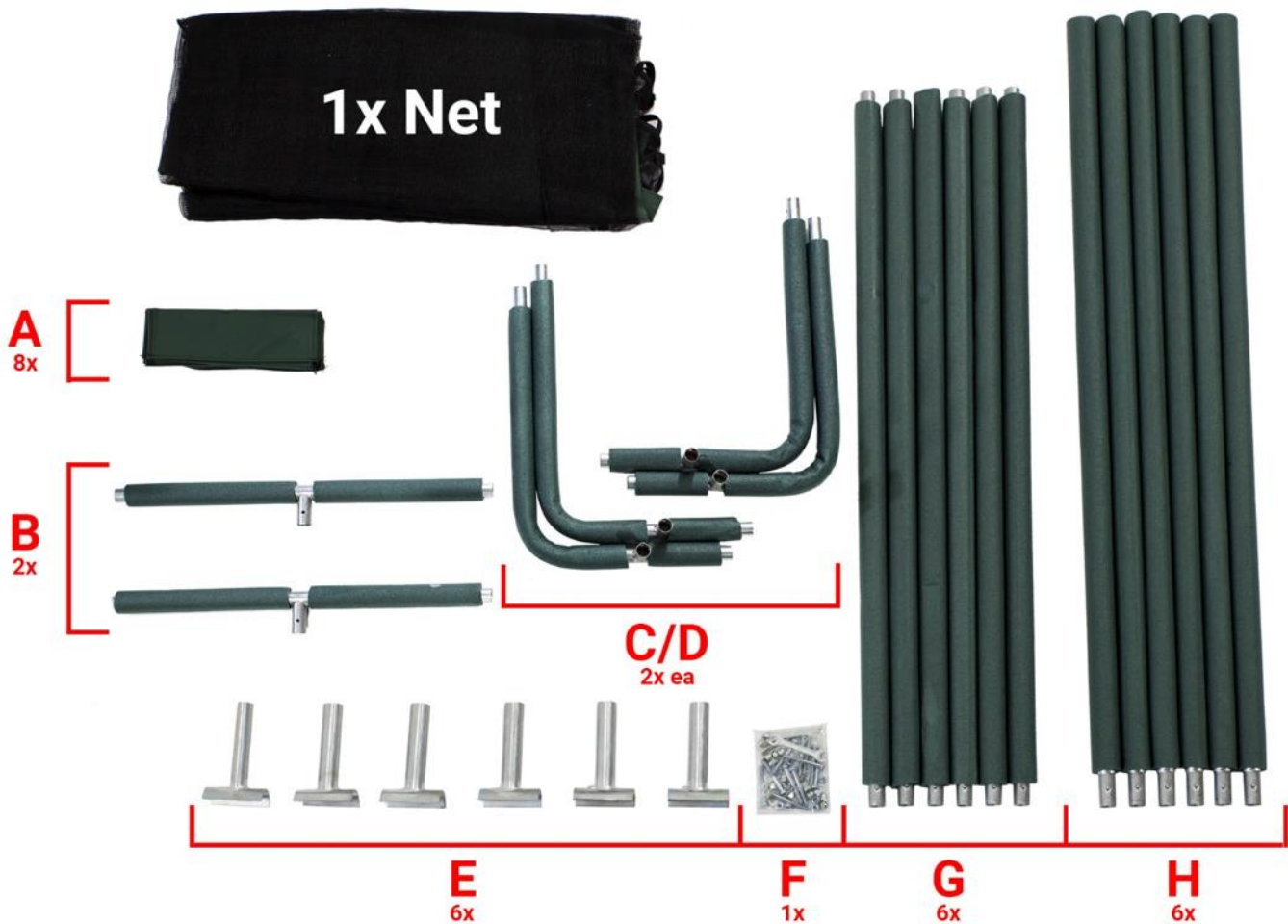

**Note:** Please ensure that the box contains all the trampoline net enclosure parts listed above. Above details the quantity of each part that you should have.

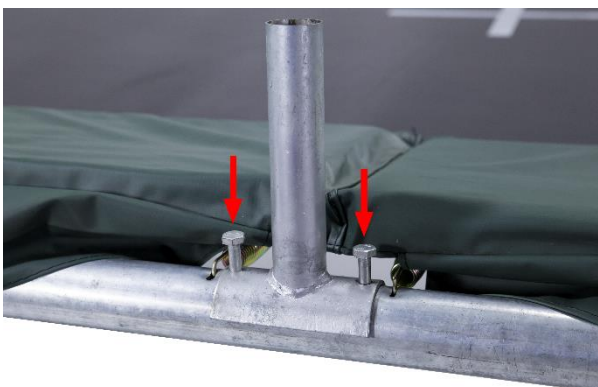

### Step 6.1

To install the net pole mounts (ref #E), line up the two bolt holes and place bolts (ref #F), through the net pole mount and frame.



### Step 6.2

Partly install the lock nuts on each bolt. Do this for all six net pole mounts.

**Note:** For ease of upper net rail assembly later, leave the nuts semi loose (about four full turns anti-clockwise from the tightened position, they will be tightened up later, near the end of the net assembly).



### Step 6.3 - (10x17 cont.)

1. Install all six vertical net pole assemblies with foam (ref #H) into the net pole mounts (ref #E).

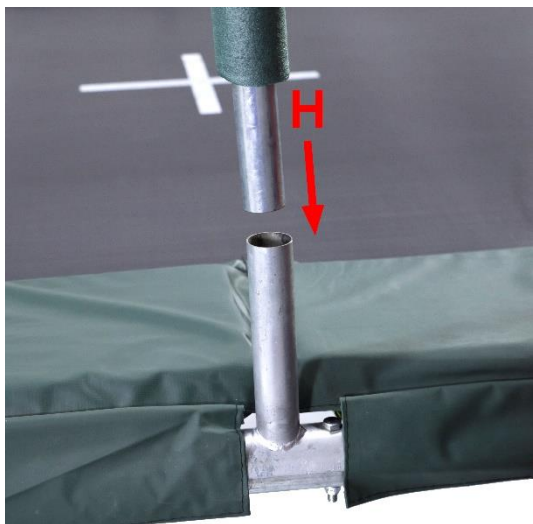

**Note:** The male end (with the spring clip installed) of the vertical net pole will be at the top.

**Note:** Rotate the vertical net poles, so the spring clip at the top points inwards towards the centre of the trampoline. This pre-aligning is handy for when you come to installing the upper net rail parts.



Your trampoline should now look like this.

### Step 6.4

1. Layout the net on the trampoline.
2. Install the safety net sleeves over all the vertical upright net poles (as shown) and gradually work (approximately 100-250mm at a time) the sleeves down to the frame.

**Note:** The entrance will only go on the long side of the trampoline (circled in red).

**Note:** The factory pre-tests the zips. However, before installing the net, ensure both zips work smoothly.

**Note:** The vertical pole sleeves go to the outside (netting to the inside).





**10x17 cont.**

Your trampoline should look like this.

**Note:** The vertical net pole circled in red is where step 6.6 starts.

**Step 6.5**

Refer to the re-sleeving steps labelled 1-2-3 in the images to the left.

1. Remove the long foam piece

2. Install half of the pole foam with sleeve (ref # A)

3. Slide the sleeved pole foam back onto the corner piece (ref # C & D). If you find it difficult to slide the foam around the corner section, then you can spray a little bit of silicon on the steel tube first.

Repeat this for all 4 corners.

**Note:** Only one sleeve is required per corner (ref # C & D)

Install sleeves (ref # A) onto the foams of all the top T-pieces (ref # B).

**Note:** The short vertical sections on all pieces will remain un-sleeved.

**Step 6.6**

For the upper net rail assembly either work from within the trampoline (remove shoes) or use a step ladder and work on the outside of the trampoline; either way, take care not to fall.

Slide the **long side** of a corner piece (ref # C & D) into the inside of the sleeve on the **short end** of the trampoline.

It should look like this.

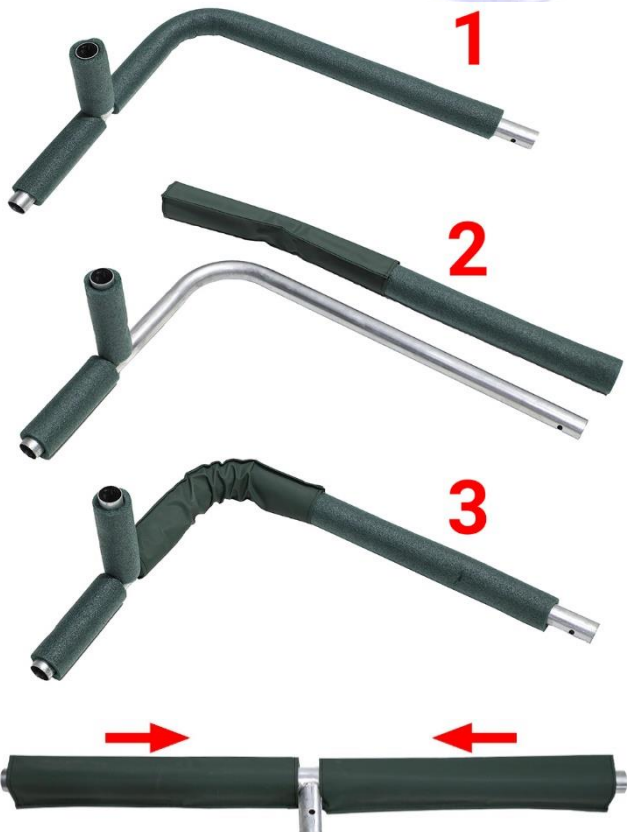



### Step 6.7 - (10x17 cont.)

1. Slide the short side of a corner piece (ref # C & D) into the inside of the short sleeve on the long side of the trampoline.



2. Align and then slide down the corner piece socket over the corresponding vertical net pole.

**Note:** You will need to push the spring clip in for it to slide on all the way. Take care not to nip a finger during this process.



3. Align the hole over the spring clip, so it clicks into place. Complete by pulling up the vertical net sleeve over the foam.

Your corner should now look like this.



### Step 6.8

Repeat steps 6.6 and 6.7 for each corner until your trampoline looks like this.



### Step 6.9

Like step 6.7, install the top T-pieces onto the centre vertical net poles. Make sure the spring clip has clicked into place.



### Step 6.10 - (10x17 cont.)

1. Slide an upper net rail piece (ref #G) into any of the six hanging sleeves.



2. Align the spring clip, so it clicks into place.



3. Do the same for the other end, so both ends of the rail are now connected and the spring clips are fully engaged.



4. Repeat this step until all six upper net rail pieces (ref #G) are secured in place.



### Step 6.11

Tighten all the lock nuts, then install and tighten all the cap nuts.

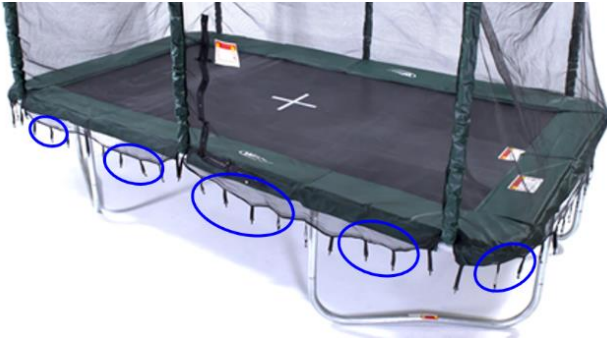

### Step 6.12 - (10x17 cont.)

1. Locate the net's elastic clips circled in blue and clip them onto the closest V-ring on the jumping mat's edge.



2. Once they're clipped on, it should look like this from underneath.



### Step 6.13

1. Locate the net's elastic clips circled in red (these are the straps at the bottom of every net pole and the top of every leg upright) and then, clip them onto the closest **frame side spring hook**.



**Note:** Cross the elastic straps, so the **left** strap at the bottom of the net pole will cross over and attach to the **right** frame end spring hook and vice versa.



**10x17 cont.**

Note: View from underneath pads

**Step 6.14**

Your trampoline is now fully assembled.

Please skip to the "Care and Maintenance Instructions."



## Step 6 - Attaching the Safety Net Enclosure (14x16ft)

### Step 6.1

Identify and familiarise yourself with the parts. Check the diagram below.

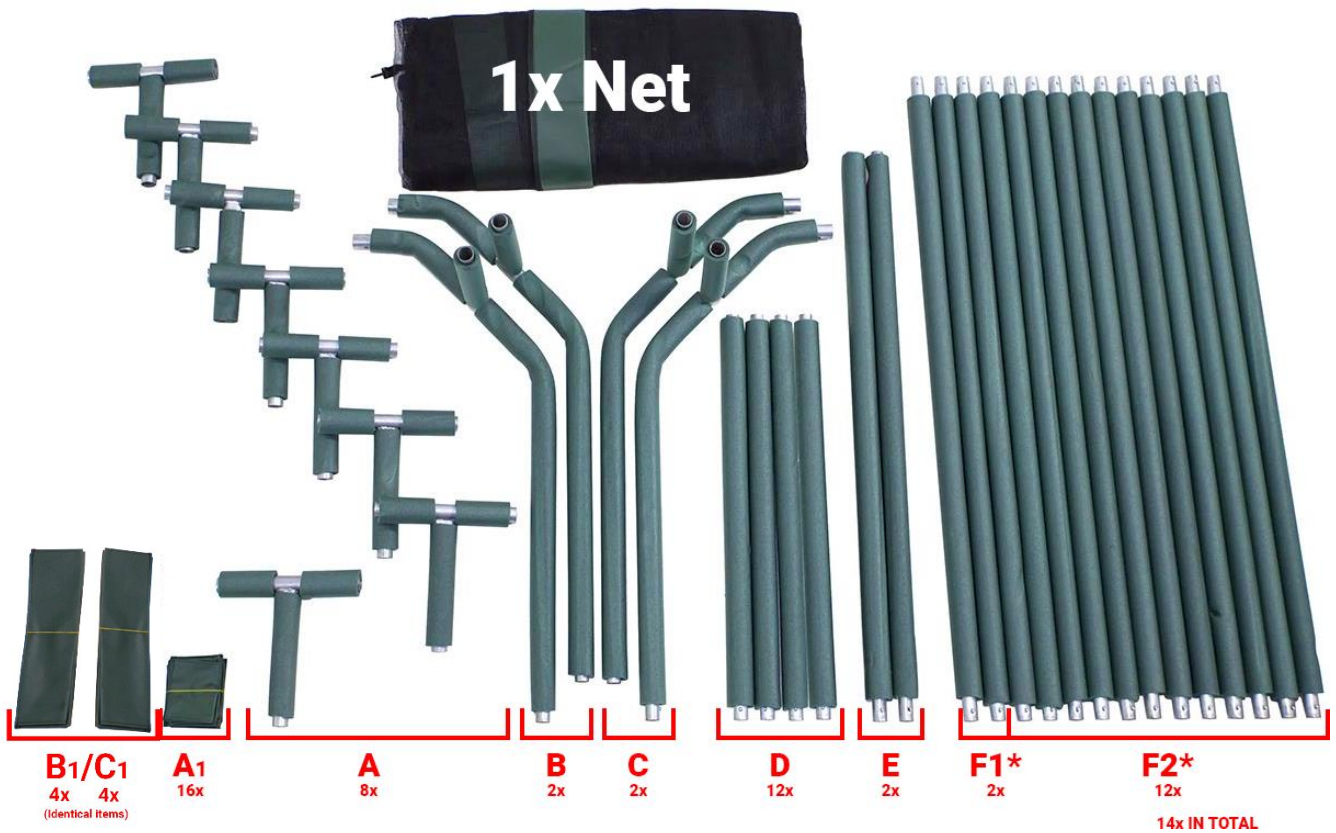

\* **Note:** F1 and F2 are the exact same part. Twelve of the 'F' poles will be used as vertical net poles (F2) and the other two of the 'F' poles will be used for the long side of the upper net rail (F1).

### Step 6.2

Familiarise yourself with the layout of the upper net rail below and refer to it if you're unsure of what piece is correct.

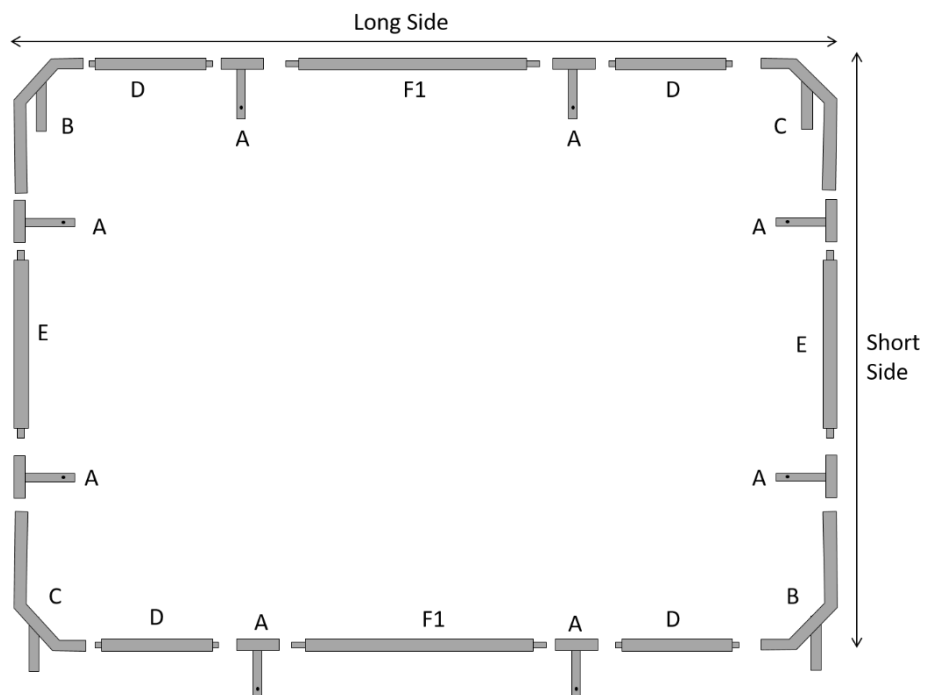



### Step 6.3 - (14x16 cont.)

Install all twelve vertical net poles (ref F2) into the frame sockets.

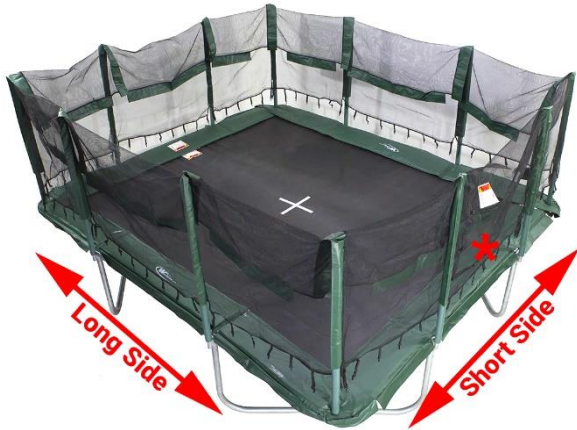

### Step 6.4

Install the safety net sleeves over all the vertical upright net poles (ref F2).

\* **Note:** The entrance can only go in the centre of the short (14ft) side of the trampoline.

**Note:** The vertical Pole sleeves will go to the outside (netting on the inside).



### Step 6.5

Gradually work (approximately 100-250mm at a time) the sleeves down to the frame.





### Step 6.6 - (14x16 cont.)

1. Locate corner pieces (ref B & C).



2. Remove pole foams from the corner pieces (ref B & C).



3. Locate PVC sleeves (ref B1 & C1).



4. Slide both sleeves (ref B1 & C1) over their corresponding pole foams.



5. Slide newly sleeved foams over corner pieces (ref B & C).

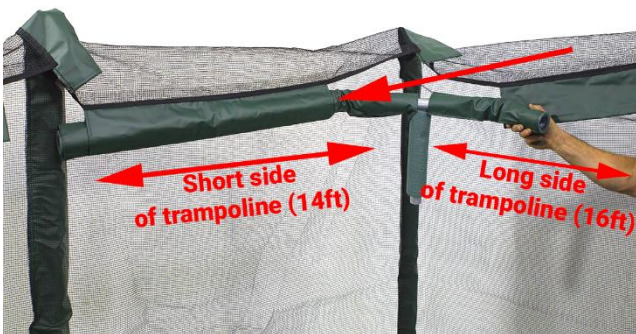

### Step 6.7

Sleeve long side of a corner piece (ref B) into the trampoline's short side sleeve.



### Step 6.8 - (14x16 cont.)

1. Insert vertical section of corner piece (ref B) into the vertical corner net pole while pressing in the spring clip and ensure it clicks into place.



2. The installed corner piece should look like this. Repeat this step until all net corner pieces are installed.



### Step 6.9

Insert all T-pieces (ref A) into the vertical net poles (ref F2). Sleeve short ends of T-piece (ref A) with the short PVC sleeves (ref A1).



### Step 6.10

Sleeve net pole (ref D) into the trampoline's long side sleeve and then join it to the corner piece (ref B), ensuring the spring clips clicks in.



### Step 6.11 - (14x16 cont.)

Insert the net pole (ref F1) into the middle net pole sleeve on the **long** side of the trampoline. Slide the net pole (ref F1) into the T-pieces (ref A) on either end and ensure the spring clips click in.



### Step 6.12

Insert net pole (ref E) into middle net pole sleeve on the **short** side of the trampoline. Slide the net pole (ref E) into the T-pieces (ref A) on either end and ensure the spring clips click in.

Repeat steps 6.7 - 6.12 until all upper rail is completely assembled.



### Step 6.13

1. Go around clipping the net clips (that are attached by elastic) to the jumping mat edge V rings.

**Note:** Clip the net clips that are near leg joints and the vertical net poles to the frame side spring hook as they won't easily reach to the jumping mat's V rings. See step 6.14.



2. Once they're clipped on, it should look like this from underneath.



#### Step 6.14 - (14x16 cont.)

Locate the net's elastic clips near the vertical net poles and legs, then, clip them onto the closest frame side spring hook.

**Note:** Cross the elastic straps, so the **left** strap at the bottom of the net poles and legs will cross over and attach to the **right** frame end spring hook and vice versa.

**Note:** View from underneath pads.



#### Step 6.15

Your trampoline is now fully assembled. Please continue to read the rest of this manual.



## LADDER INSTALLATION

### Installing the Ladder (All Sizes)



The ladder provided is an important safety device, ensure correct installation.

Do not place on the outside of the netting. Take notice of how the top ladder hooks.

### Ladder Location (All Sizes)

The ladder is placed in line with the net entrance, the left hand side of the ladder lines up with the vertical zip.

- 7x10ft, 8x12ft, 9x14ft, & 10x17ft: The ladder can only go on the **long side**.
- 14x16ft: The entrance can only go on the **short side**.

## Step 7 - Attaching the Ladder

### Step 7.1

Undo the net straps in the immediate area of where the ladder will be located.

### Step 7.2

Place the ladder top hooks directly onto the trampoline frame.

**Note:** Do not install the ladder top hooks over any netting, the netting will go on the outside.

Ensure both ladder feet are evenly loaded onto firm ground.

**Note:** The ladder should have even fitting with all contact points with the frame and the ground, the ladder should not rock side to side.

### Step 7.3

Re-fit the net straps, connect onto the frame end spring hook

**Note:** Ensure the net straps are not loose

## CARE AND MAINTENANCE INSTRUCTIONS

### Maximum User Weight Limit

The trampoline and the net enclosure have been designed to allow for the safe use by a single person at a time. It is recommended that the user does not exceed the maximum user weight rating as shown:

| Trampoline Size | Maximum User Weight |
|-----------------|---------------------|
| 7x10ft          | 130kg               |
| 8x12ft          | 150kg               |
| 9x14ft          | 150kg               |
| 10x17ft         | 150kg               |
| 14x16ft         | 150kg               |

### Pre-Use Checks

The pre-use checks in this manual will highlight any ongoing repairs required or items to be addressed that will preserve the life of the trampoline. See the following for some additional ongoing care tips.

### Frame

The frame works best on a level surface; if the trampoline is used on a surface that's not level the frame will need to absorb uneven localised loads that could be above the design capacity. Keep the legs and net poles perpendicular to keep the loads evenly distributed.

### Frame Corrosion

The steel parts are primarily protected from corrosion by a galvanised coating, this, however, can be affected by some substances e.g. some soils are very acidic. The galvanised layer is, by design, a sacrificial coating and a scratch through this surface to the base steel will still be protected. Any deterioration of a damaged area of the galvanised coating can be prevented further by applying a suitable aftermarket spray paint.

### Bed (Mat) & Pads

Residual substances from dust storms, chemical spraying, etc. on the trampoline surface can cause rapid wear or create an abrasive surface for the user, simply wash off with cold water and let it dry before using the trampoline. Be aware if the pads are not in place the edge stitching on the mat becomes fully exposed to the sun's UV, reducing mat lifespan.

### Bed (Mat) Use

The bed and suspension system are designed to last well if most of the jumping is primarily done in the centre. Be aware that trampoline accessories like a basketball set can in some cases inadvertently cause concentrated use away from the centre of the bed.

### Net Zip

A pure silicon lubricant spray applied to the zip section will keep the zip from binding up. Take care not to overspray or drip onto other parts of the trampoline (creating a slippery surface).

### Net Pole Foam

Be aware that sharp objects and full sunlight can cause deterioration over time.

## Date of Purchase

Record your purchase date here      ...../...../.....

**Note:** The trampoline components deteriorate naturally with use and time in the environmental conditions such as sunlight, rain, salt and heat. Also bear in mind that unexpected mishaps from misuse, extreme weather and other causes can have an immediate effect on the safe condition of the trampoline. It is important that you inspect the trampoline before each use and replace any worn, defective or missing parts before further use. Use only parts that are recommended by the manufacturer. Consider below when doing pre-use or regular maintenance checks.

### Potential Hazards of Trampoline Components

| <b>Trampoline Frame</b>                    | <b>Trampoline Bed<br/>(Jumping mat)</b>   | <b>Frame Padding</b>  | <b>Enclosure System<br/>(Safety net)</b>   |
|--|---|---|--|
| Bending or fracture of the frame.          | Punctures, holes, fraying, tears in the bed or edge system.                         | Padding partially or completely missing.  | Missing enclosure.   |
| Loose or un-sturdy framework.              | Stitching or fabric deteriorating of the bed and its edge system.                   | Padding insecurely attached or not positioned correctly.                          | Improperly positioned or insecurely attached;<br>net,<br>net poles<br>net pole brackets<br>net pole caps |
| Sharp protrusions on the frame.            | Sagging of the bed.   | Punctures, frays, tears or holes in the padding.                                  | Punctures, frays, tears, holes in the enclosure.   |
| Broken, missing or over stretched springs. | Sharp protrusions in the suspension system elements e.g. damaged or broken springs. | Stitching or padding fabric deteriorating of the padding and its securing system. | Damage to net pole padding or net pole sleeve.   |
|  |   | Damaged or degenerated padding.   | Stitching or fabric deteriorating of the enclosure and its securing system.                              |
|  |   |   | Sagging of the netting.  |
|  |   |   | Bent, broken or sharp protrusions on the net poles.  |
|  |   |   | Broken or damaged enclosure entrance system.   |

## USER INSPECTION CHECKLIST

A trampoline in poorly maintained condition will increase your risk of getting injured. Please inspect the trampoline before each use, check for damaged or worn parts, for example:

|   |        |
|---|--------|
| Date of inspection:     /     /   | ✓ or X |
| <b>Trampoline Positioning</b>   |        |
| Trampoline is positioned, stable and on a level surface   |        |
| Trampoline is positioned on a soft surface (e.g. well grassed)  |        |
| Trampoline is positioned a minimum of 1.5m away from hard surfaces and other potential hazards (e.g. walls, fences, clotheslines and trees) |        |
| Adequate clearance is provided above the trampoline bed (minimum 5m)  |        |
| The space under the trampoline is clear of objects (e.g. bikes, mower, garden tools, toys)  |        |
| <b>Trampoline Frame</b>   |        |
| Frame is in good condition (e.g. not bent or broken, no rust or corrosion)  |        |
| Legs are inserted fully, secure and locked in position  |        |
| Joints are in good condition (e.g. no signs of stress, cracks, rust or corrosion)   |        |
| Frame does not present sharp protrusions or edges   |        |
| <b>Trampoline Suspension System</b>   |        |
| Suspension system is in good condition (e.g. springs are not over stretched or damaged, not bent or broken, no rust or corrosion)           |        |
| Suspension system is complete (e.g. all springs are present and connected)  |        |
| Suspension system does not have sharp protrusions or edges  |        |
| <b>Trampoline bed (jumping surface)</b>   |        |
| Bed is in good condition (e.g. no punctures, tears, holes, sagging or other damage)   |        |
| Fabric and stitching of the bed is in good condition  |        |
| <b>Padding (where required)</b>   |        |
| Padding is correctly installed and securely attached to exposed framework & mat edges   |        |
| Padding is in good condition (e.g. no punctures, tears, holes or other damage)  |        |
| Stitching of padding fabric and securing is in good condition   |        |
| <b>Enclosure</b>  |        |
| Enclosure and supports are correctly installed, securely attached and in good condition   |        |
| Pole caps (where required) are installed and securely attached  |        |
| Enclosure is in good condition (e.g. no punctures, tears, holes, sagging or other damage)   |        |
| Stitching of the enclosure is in good condition   |        |
| Enclosure support structure does not present sharp protrusions  |        |
| Enclosure entrance is in good condition and not broken or damaged   |        |
| Enclosure zips (if installed) close the entrance securely and freely  |        |

Any items marked "X" requires maintenance, repair or modification (e.g. repositioning, etc.).

Refer to the instruction manual or contact the supplier for further information.



**Warning:** If any of the above problems are present or any additional problems arise that could cause the user harm then the trampoline should not be used until the problem is rectified.